

TECNA®

Resistance Welding Systems & Balancers



General Catalogue Balancers

CAPACITY 0,2 ÷ 180 kg



dguv.de/dguv-test

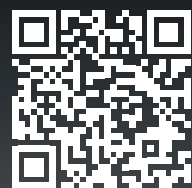

www.tecna.net



TECNA S.P.A. - VIA MEUCCI, 27 - CASTEL SAN PIETRO TERME

TECNA produces and distributes a complete range of BALANCERS having a capacity from 0.2 kg to 180 kg and an available standard wire stroke up to 3 meters. The TECNA BALANCER is an essential device to eliminate the operator's labour, to increase productivity by cutting down tools handling time and to improve work quality. Furthermore, the use of the TECNA BALANCERS reduces hoses and cables wear and avoids eventual damages to both people and tools.

The application of the TECNA BALANCER is absolutely versatile: it may be used for bench or assembly line works and it may be suitably applied to small tools, industrial suspended welders and multiple screw drivers. The ergonomic structure of the TECNA balancers has been designed to facilitate each application of use, ranging from movement easiness to body robustness, from simple use to lifting power. TECNA, as a primary manufacturer, realizes special as well as customized versions upon demand.



TECNA S.P.A. - VIA GR



Fabbricato in Italia





TECNA, 25/27 - CASTEL SAN PIETRO TERME



YOU ARE IN GOOD HANDS



TECNA BALANCERS are manufactured in Italy, following the highest quality standards, built to last and to help you work with best performance and ergonomics. We make your life better. **TECNA BALANCERS** are essential in eliminating operator fatigue and injuries, increasing productivity by reducing cycle times and improving the quality of the production.

TECNA BALANCERS safeguard your tools, hoses and cables thus increasing their lifetime and your productivity.

TECNA is a leading worldwide manufacturer. Products, spare parts and assistance can be found easily anywhere and everywhere. Just contact us if you don't know a local dealer and we'll support you and guide you to the closest Tecna distributor.

Some numbers game:

Almost 6.000.000 **TECNA BALANCERS** manufactured. TECNA sells on average more than 160.000 BALANCERS per year, with more than 300 different models and possibility of further customisation. One of the most complete range of products available on the market, with load range up to 180kg (400lbs) and rope stroke up to 4,5m (14ft).

More than 2.000 hours of R&D per year are dedicated to product development for balancers. 4 registered patents. 3 new patents pending.

You are in good hands.

AND there's a lot more to TECNA than just a large structure and big numbers. There's competence, there's professionalism, there's thought, there's flexibility. There's PEOPLE. We're here to listen and to provide solutions wherever possible. We're fast, we're flexible. We can handle urgency and we can handle special requests.

TECNA BALANCERS are SAFEST.

All balancers are manufactured in conformity with the DIN 15112 Directive.

All TECNA PRODUCTS undergo thorough testing to ensure maximum safety and performance in time. Breaking load is guaranteed minimum 5 times the declared maximum load for all sensible parts.

Cables are bare, in order to ensure quick visual inspection. TECNA offers cable choice: Stainless steel, Dyneema® or Polypropylene.

Different materials on cables allow **TECNA BALANCERS** to be used in many different situations, for example where a steel cable might scratch delicate objects.

Innovation and improvement are constant and continuous.

TECNA BALANCERS behave excellently and prove their rugged sturdiness also in extreme working conditions, such as heavy duty applications, meat processing industry, outdoor conditions, as well as extremely repeating high-rate uses on assembly lines tool suspension, where long life means higher production.

TECNA was the first to develop a dedicated line with ATEX certification, suitable for use in areas with a potentially explosive atmosphere composed of flammable gases or combustible materials.

TECNA BALANCERS are good and tough and allow you to do a lot more than just suspend loads or tools. Just use them and you will see, the only limit is your creativity. And when you don't find an answer, just contact us and we'll listen. **TECNA BALANCERS** are just so good that you can forget about them... but don't forget to use them!

RETRACTORS



Use your instrument with minimum effort
When released, the load will return to its rest position



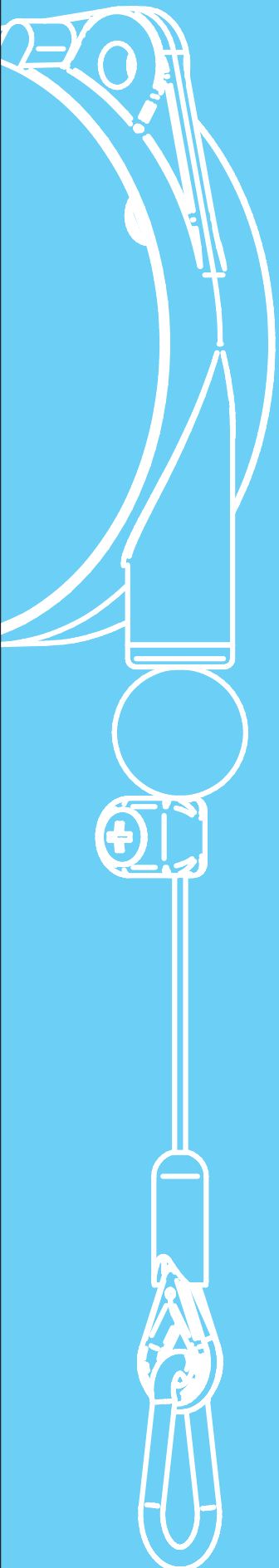

Stainless steel rope

01



HSM 21023

dguv.de/dguv-test

	Nylon
	1600 mm
	Stainless Steel
	0,2÷3 kg

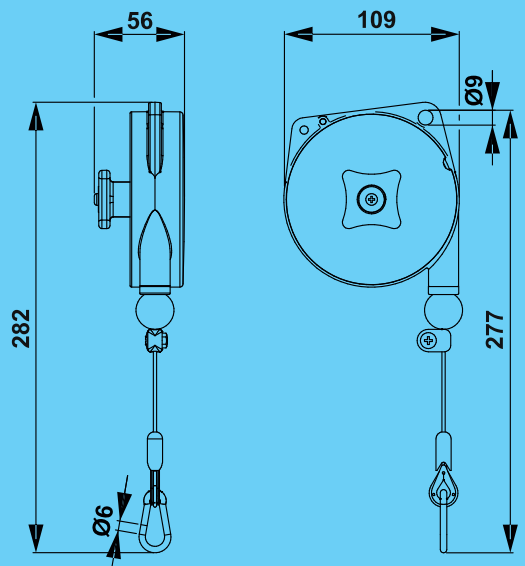

Item	9300	9301	9302	9303
**	0,2÷0,5	0,4÷1	1÷2	2÷3
	0,43	0,46	0,49	0,64

02



HSM 21023

dguv.de/dguv-test

	Aluminium
	1600 mm
	Stainless Steel
	0,2÷3 kg

03



HSM 21023

dguv.de/dguv-test

	Aluminium
	2000 mm
	Stainless Steel
	1÷8 kg

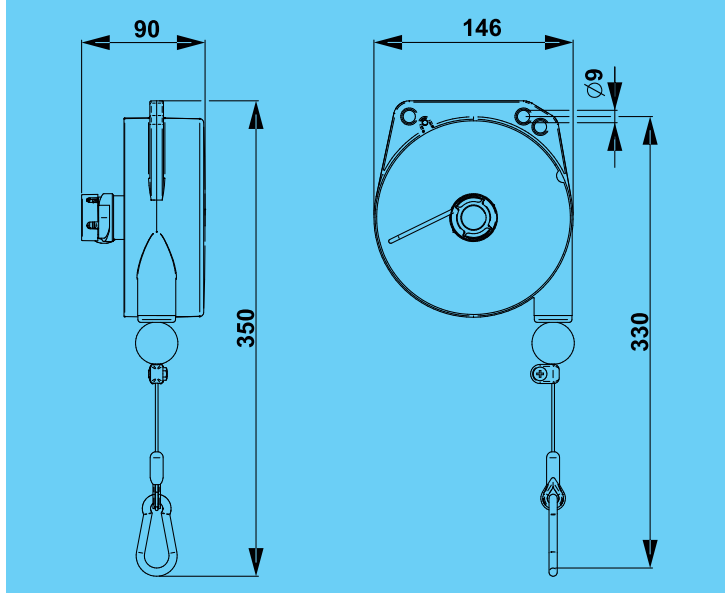
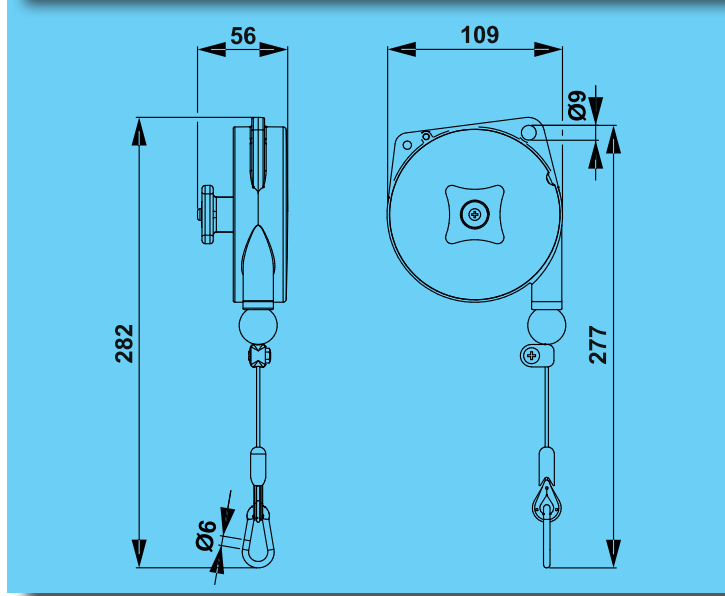

Item	9310	9311	9312	9313
	0,2÷0,5	0,4÷1	1÷2	2÷3
	0,55	0,57	0,60	0,74

Item	9320	9321	9322	9323
	1÷2,5	2÷4	4÷6	6÷8
	1,67	1,90	1,98	2,28

9336L÷9340

9346L÷9350

04



HSM 21023

gs.de/dguv-test

	Aluminium
	2500 mm
	Stainless Steel
	0,5÷14 kg



Opz. 32952

Flexible cables holder (Max. load capacity 25kg)

05

STOP



HSM 21023

gs.de/dguv-test

	Aluminium
	2500 mm
	Stainless Steel
	0,5÷14 kg

These balancers are equipped with a device enabling to stop the stroke by carrying out a simple operation on the load and with a device that disables it.

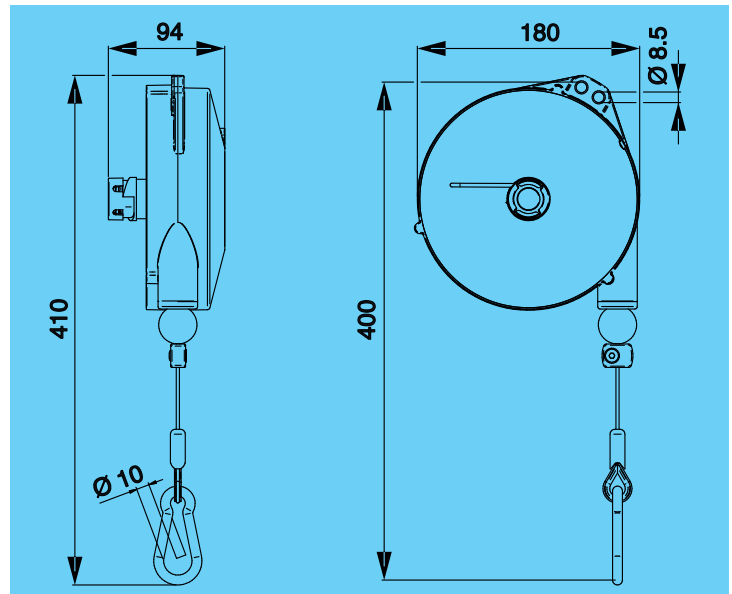
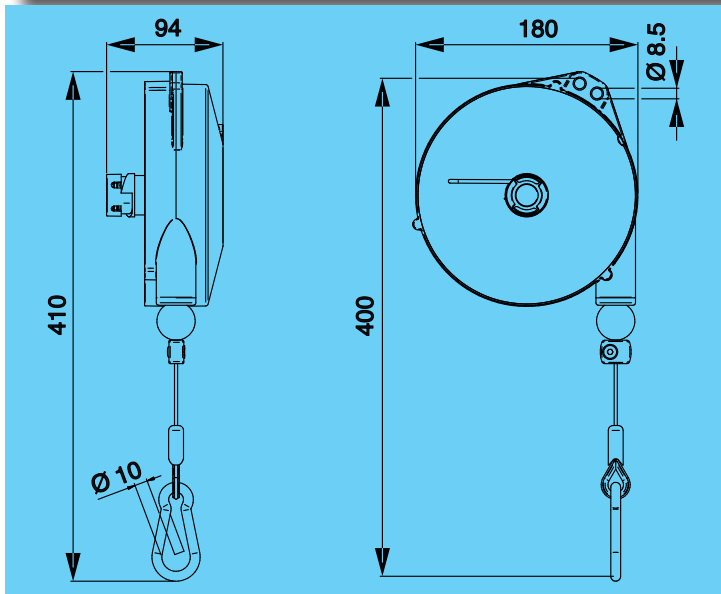

Item	9336L	9336	9337	9338	9339	9340
	0,5÷2	2÷4	4÷6	6÷8	8÷10	10÷14
	3,14	3,14	3,30	3,36	3,43	3,58

Item	9346L	9346	9347	9348	9349	9350
	0,5÷2	2÷4	4÷6	6÷8	8÷10	10÷14
	3,14	3,14	3,32	3,38	3,48	3,62

AIR HOSE GROUP for 9310÷9313

AIR HOSE GROUP for 9320÷9323

06



Hose
Øi 8mm/ Øe10mm

The maximum operating pressure is 10 bar

7010000017

9310÷9313

08



Hose
Øi 8mm/ Øe10mm

The maximum operating pressure is 10 bar

7010000015

9320÷9323

7010000028

9320/4,5÷9323/4,5

07



Hose
Øi 11mm/ Øe16mm

The maximum operating pressure is 10 bar

7010000018

9310÷9313

09



Hose
Øi 11mm/ Øe16mm

The maximum operating pressure is 10 bar

7010000016

9320÷9323

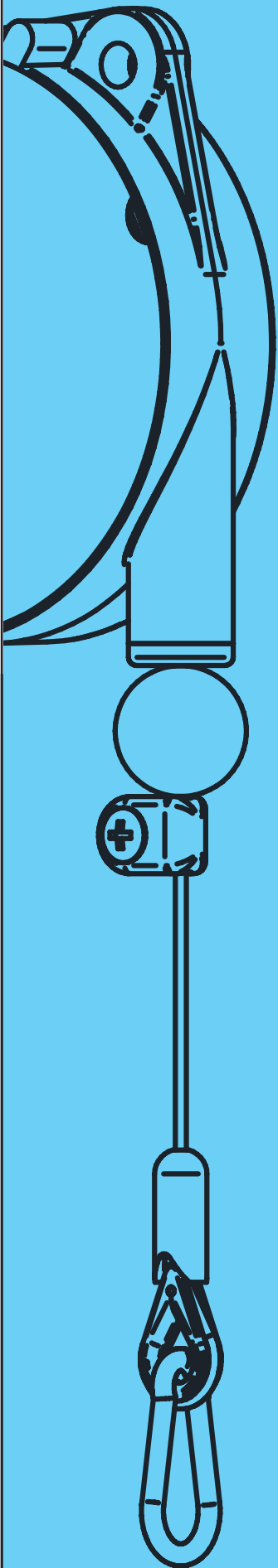

Polypropylene & Dyneema® rope

10



HSM 21023

	Nylon
	1600 mm
	Polypropylene
	0,2÷3 kg

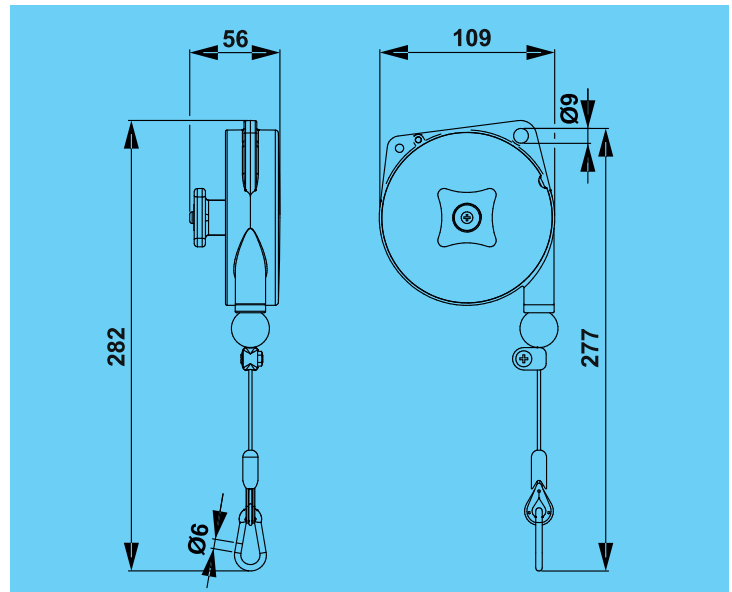

Item	9300NY	9301NY	9302NY	9303NY
	0,2÷0,5	0,4÷1	1÷2	2÷3
	0,43	0,46	0,49	0,64

9310NY÷9313NY

9320NY÷9323NY

11



	Aluminium
	1600 mm
	Polypropylene
	0,2÷3 kg

12



	Aluminium
	2000 mm
	Polypropylene
	1÷8 kg

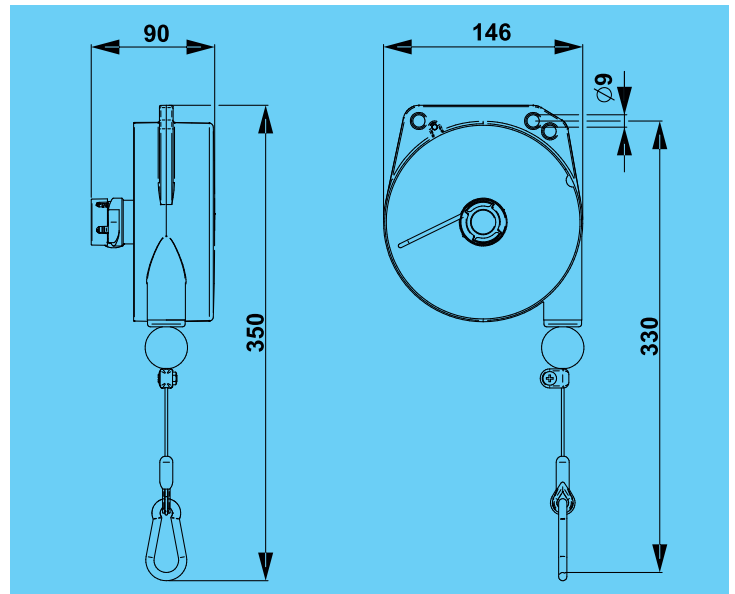
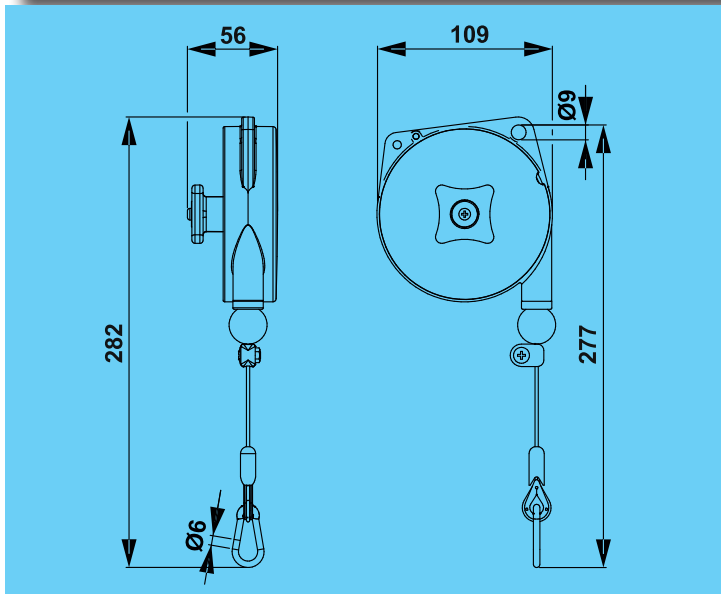

Item	9310NY	9311NY	9312NY	9313NY
	0,2÷0,5	0,4÷1	1÷2	2÷3
	0,55	0,57	0,60	0,74

Item	9320NY	9321NY	9322NY	9323NY
	1÷2,5	2÷4	4÷6	6÷8
	1,67	1,90	1,98	2,28

9336LNY ÷ 9340NY

9346LNY ÷ 9350NY

13



HSM 21023

	Aluminium
	2500 mm
	Dyneema®
	0,5 ÷ 14 kg



Opz. 32952

Flexible cables holder (Max. load capacity 25kg)

14

STOP



HSM 21023

	Aluminium
	2500 mm
	Dyneema®
	0,5 ÷ 14 kg



These balancers are equipped with a device enabling to stop the stroke by carrying out a simple operation on the load and with a device that disables it.

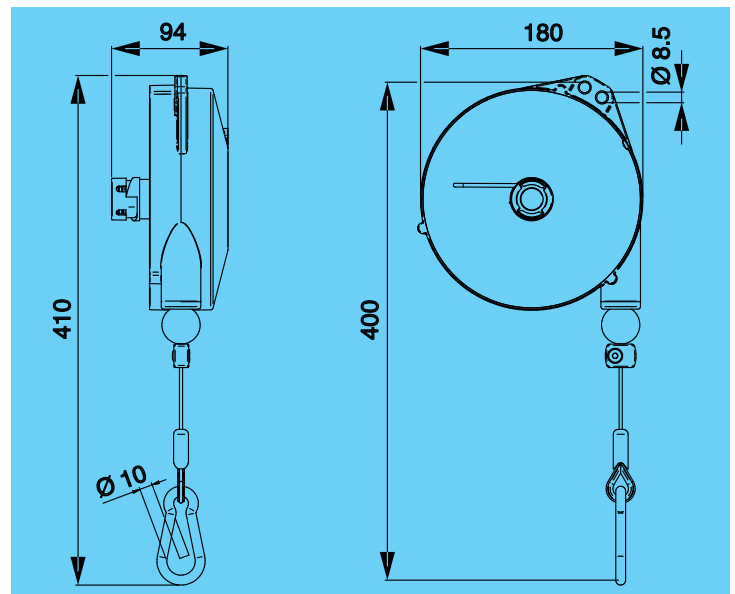
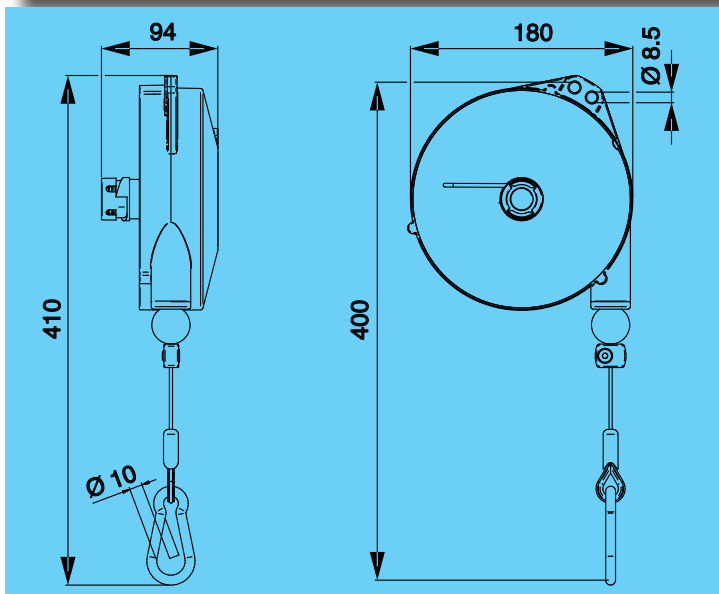

Item	9336LNY	9336NY	9337NY	9338NY	9339NY	9340NY
	0,5 ÷ 2	2 ÷ 4	4 ÷ 6	6 ÷ 8	8 ÷ 10	10 ÷ 14
	3,14	3,14	3,30	3,36	3,43	3,58

Item	9346LNY	9346NY	9347NY	9348NY	9349NY	9350NY
	0,5 ÷ 2	2 ÷ 4	4 ÷ 6	6 ÷ 8	8 ÷ 10	10 ÷ 14
	3,14	3,14	3,30	3,36	3,43	3,58

15



Hose
Øi 8mm/ Øe10mm

The maximum operating pressure is 10 bar

7010000017

9310NY÷9313NY

17



Hose
Øi 8mm/ Øe10mm

The maximum operating pressure is 10 bar

7010000015

9320NY÷9323NY

16



Hose
Øi 11mm/ Øe16mm

The maximum operating pressure is 10 bar

7010000018

9310NY÷9313NY

18



Hose
Øi 11mm/ Øe16mm

The maximum operating pressure is 10 bar

7010000016

9320NY÷9323NY

BLOWING IN THE WIND

NEW



TECNA proposes a complete line of AIR HOSE BALANCERS and AIR HOSE SPIRAL ACCESSORIES, perfect for balancing and working ergonomically with AIR TOOLS.

The various declinations of AIR HOSE BALANCERS models and of AIR HOSE SPIRAL ACCESSORIES allow you to always find the perfect solution with any air tool, from a screwdriver to a trimmer or a cutter, from an air gun to an impact wrench.

Thanks to their light weight and perfect balancing capability, **TECNA BALANCERS** are a perfect match with your daily work.

Solidity and reliability make **TECNA BALANCERS** an excellent friend of any workbench and working position, whether you are standing or sitting, supporting weight, balancing loads and improving the efficiency and performance of the whole process.

TECNA BALANCERS can follow you wherever you go, wherever you work. Just use them and you will see, the only limit is your creativity. And when you don't find an answer, just contact us and we'll listen.

19

Used for arranging ergonomic work stations.

Applications: Screw drivers - Drills - Shearing machines - Tools for electronics - Air guns.

ADVANTAGES

- Maximum ease of use.
- Minimum overall dimensions as the tool is supported by the hose.
- Polyurethane hose.
- Rugged construction, cast aluminium body.
- Adjustable capacity.
- Springs properly sized to ensure long life and smooth running.
- Adjustable stroke limiting device.
- Auxiliary safety suspension.



Aluminium	
	1350 mm 9200÷9202
	900 mm 9203
Polyurethane	
	0,4÷5 kg

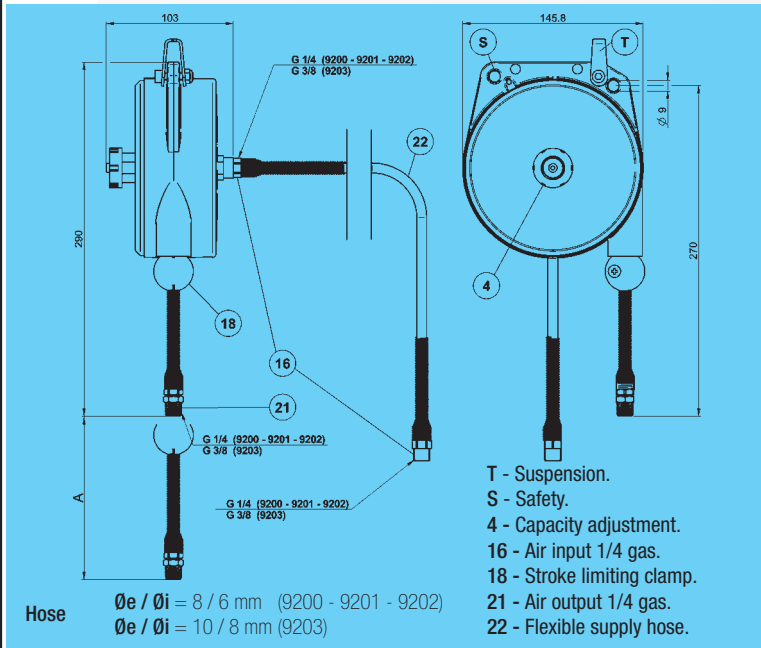

Max operating pressure:
8 bar
Max operating temperature:
50°

Item	9200	9201	9202	9203 (GS excluded)
	1,25	1,30	1,35	1,35
	0,4÷0,8	0,75÷1,5	1,2÷2,5	3÷5

BALANCERS TECHNICAL FEATURES

	9300÷9303 9300NY÷9303NY	9310÷9313 9310NY÷9313NY	9320÷9323 9320NY÷9323NY	9336L÷9340 9336LNY÷9340NY	9346L÷9350 9346LNY÷9350NY	
kg	0.2÷3	0.2÷3	1÷8	0,5÷14	0,5÷14	Capacity
mm	1600	1600	2000	2500	2500	Stroke
	●					Rugged construction, Nylon body
		●	●	●	●	Rugged construction, cast aluminium body
	●1	●2	●3	●4	●5	Stainless steel rope
	●10	●11	●12	●13	●14	Polypropylene / Dyneema rope, for «NY» model
	●	●	●	●	●	Adjustable capacity
	●	●	●	●	●	Safety suspension
			●	●	●	Safety device against load dropping due to the spring breakage (capacity >3kg)
	●	●	●	●	●	Adjustable stroke limiting device
	●	●	●	●	●	Cable guide in antifriction material
	●	●	●	●	●	Inert spring drum assembly
	●	●	●	●	●	Polyamides thimble

ON REQUEST 32952

32952			●	●	●	Flexible cables holder (Max. load capacity 25kg)
-------	--	--	---	---	---	--

PACKAGING FEATURES

	9300 9300NY	9301 9301NY	9302 9302NY	9303 9303NY	9310 9310NY	9311 9311NY	9312 9312NY	9313 9313NY	9320 9320NY	9321 9321NY	9322 9322NY
kg	0.50	0.60	0.60	0.70	0.50	0.60	0.60	0.70	1,80	2,1	2,1
lb	1.10	1.32	1.32	1.54	1.10	1.32	1.32	1.54	3.97	4.63	4.63
mm	204x112x62	204x112x62	204x112x62	204x112x62	204x112x62	204x112x62	204x112x62	204x112x62	254x149x96	254x149x96	254x149x96
inch	6.3x4.7x2.4	6.3x4.7x2.4	6.3x4.7x2.4	6.3x4.7x2.4	6.3x4.7x2.4	6.3x4.7x2.4	6.3x4.7x2.4	6.3x4.7x2.4	10x5.87x3.78	10x5.87x3.78	10x5.87x3.78
●	1/10	1/10	1/10	1/10	2/11	2/11	2/11	2/11	3/12	3/12	3/12
	9323 9323NY	9336L 9336LNY	9336 9336NY	9337 9337NY	9338 9338NY	9339 9339NY	9340 9340NY	9346L 9346LNY	9346 9346NY	9347 9347NY	9348 9348NY
kg	2.5	3.40	3.40	3.60	3.70	3.70	3.80	3.40	3.40	3.60	3.70
lb	5.51	7.50	7.50	7.94	8.16	8.16	8.38	7.50	7.50	7.94	8.16
mm	254x149x96	304x186x100	304x186x100	304x186x100	304x186x100	304x186x100	304x186x100	304x186x100	304x186x100	304x186x100	304x186x100
inch	10x5.87x3.78	11.97x7.32x3.94	11.97x7.32x3.94	11.97x7.32x3.94	11.97x7.32x3.94	11.97x7.32x3.94	11.97x7.32x3.94	11.97x7.32x3.94	11.97x7.32x3.94	11.97x7.32x3.94	11.97x7.32x3.94
●	3/12	4/13	4/13	4/13	4/13	4/13	4/13	5/14	5/14	5/14	5/14
	9349 9349NY	9350 9350NY	9200	9201	9202	9203	7010000017	7010000018	7010000015	7010000016	7010000028
kg	3.80	3.90	1.40	1.40	1.60	1.60	0.45	0.65	0.48	0.68	0.48
lb	8.38	8.60	3.09	3.09	3.53	3.53	0.99	1.43	1.06	1.50	1.06
mm	304x186x100	304x186x100	225x160x110	225x160x110	225x160x110	225x160x110	304x186x100	304x186x100	304x186x100	304x186x100	304x186x100
inch	11.97x7.32x3.94	11.97x7.32x3.94	8.86x6.30x4.33	8.86x6.30x4.33	8.86x6.30x4.33	8.86x6.30x4.33	11.97x7.32x3.94	11.97x7.32x3.94	11.97x7.32x3.94	11.97x7.32x3.94	11.97x7.32x3.94
●	5/14	5/14	19	19	19	19	6/15	7/16	8/17	9/18	8

TECNA S.p.A. Specifications subject to change without notice.

ZERO GRAVITY BALANCERS

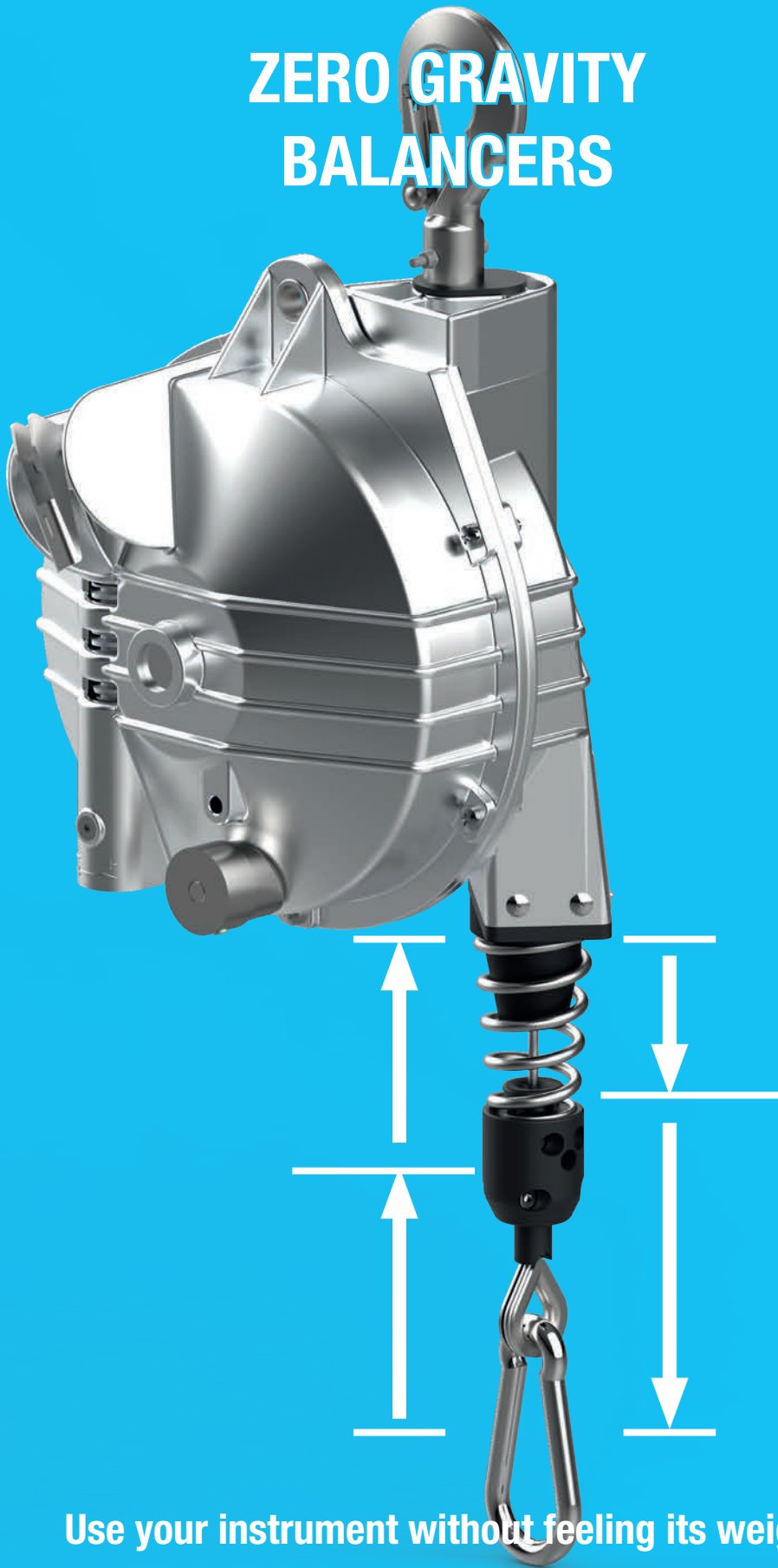

**Use your instrument without feeling its weight
The load maintains the position where you leave it**

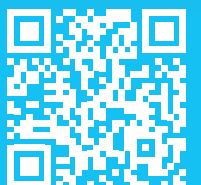

9354÷9359

9354G÷9359G

*Option F



	Aluminium
	2000 mm
	Stainless Steel
	4÷25 kg

Option RI (70477)

Rotary and insulating device.

***Option F**

The balancer is equipped with a friction/brake which controls the rotation speed of the drum.

* This option is feasible when placing a new order while it is not possible to assemble this device on balancers already installed.

*Option F

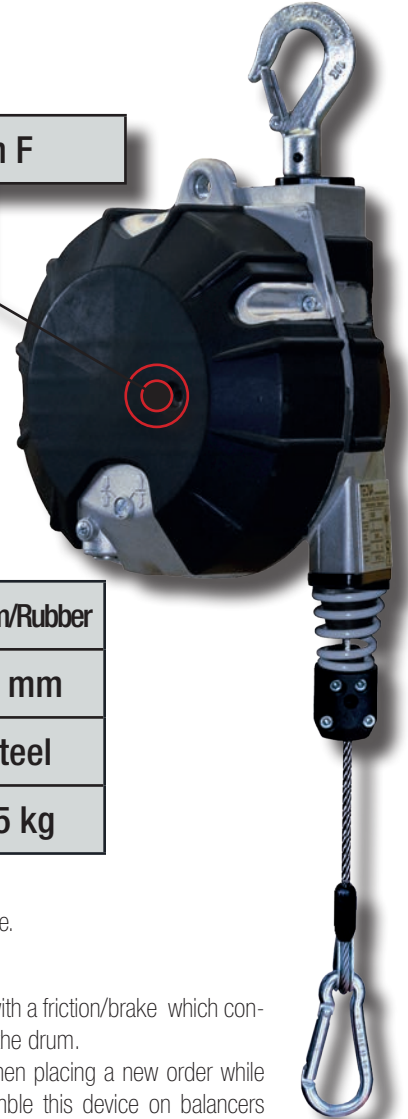

	Aluminium/Rubber
	2000 mm
	Stainless Steel
	4÷25 kg

Option RI (70477)

Rotary and insulating device.

***Option F**

The balancer is equipped with a friction/brake which controls the rotation speed of the drum.

* This option is feasible when placing a new order while it is not possible to assemble this device on balancers already installed.

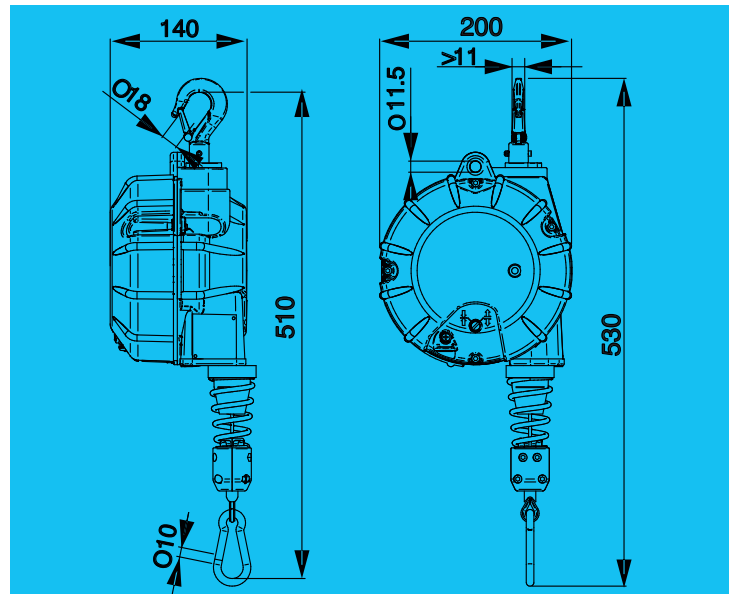
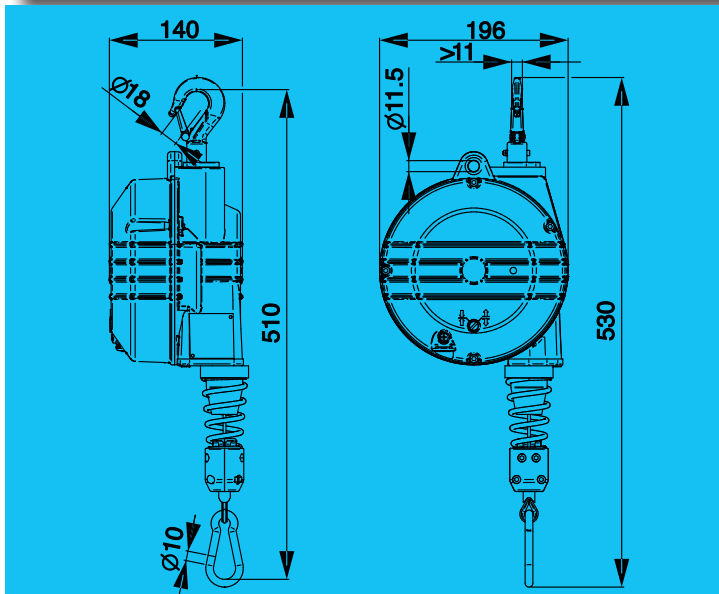

Item	9354	9355	9356	9357	9358	9359
	4÷7	7÷10	10÷14	14÷18	18÷22	22÷25
	4,94	5,30	5,67	6,26	5,89	6,53

Item	9354G	9355G	9356G	9357G	9358G	9359G
	4÷7	7÷10	10÷14	14÷18	18÷22	22÷25
	5,58	5,93	6,31	6,90	6,53	7,17

22



	Aluminium	
	2100 mm	9502÷9509
	2700 mm	9520÷9525
	Stainless Steel	
	12÷100 kg	

***Option F**

The balancer is equipped with a friction/brake which controls the rotation speed of the drum.

* This option is feasible when placing a new order while it is not possible to assemble this device on balancers already installed.

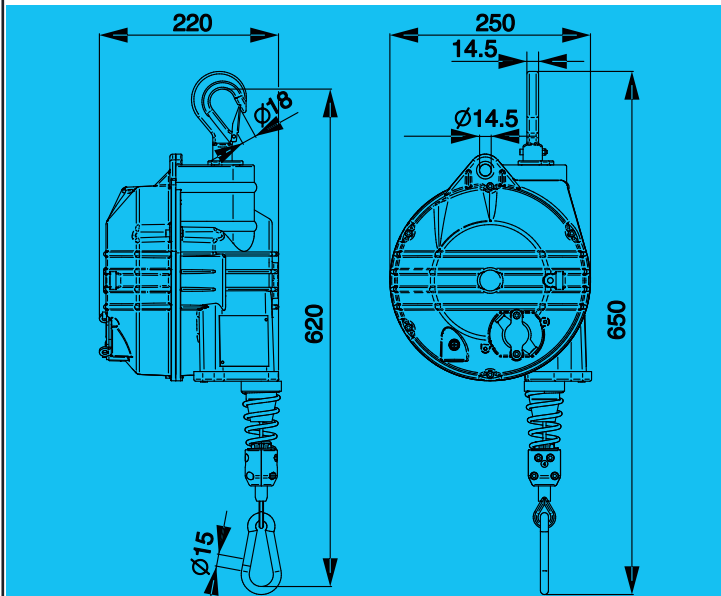

*Option F

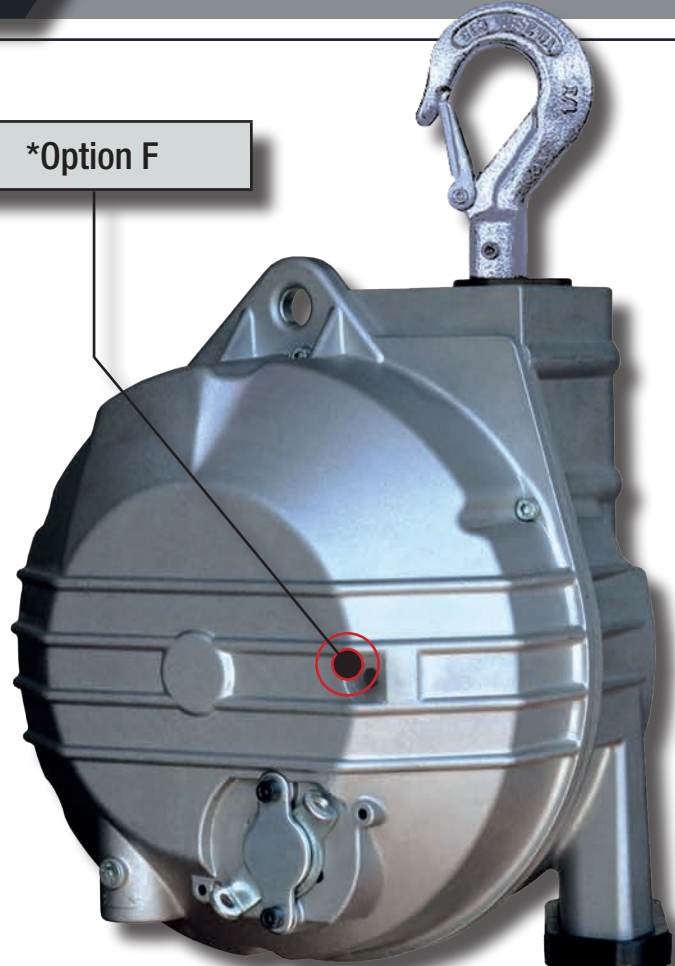

Option B
(719000007)

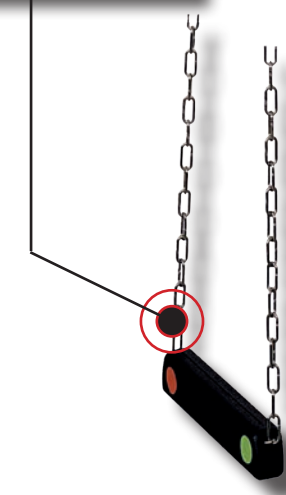

Option RI (70477)
Rotary and insulating device.

Option B (719000007)
Locking-unlocking device with control from the floor.

Item	9502	9503	9504	9505	9506	9507	9508	9509	9520	9521	9522	9523	9524	9525
**	20÷30	30÷40	40÷50	50÷60	60÷70	70÷80	80÷90	90÷100	12÷20	20÷30	30÷40	40÷50	50÷60	60÷70
	12,60	15,20	15,50	16,70	15,50	17,70	16,20	16,80	12,80	12,60	15,80	15,40	16,60	15,70

23



	Aluminium
	2000 mm
	Stainless Steel
	10 ÷ 75 kg

Option RI (70477)
Rotary and insulating device.

***Option B**
Locking-unlocking device with control from the floor.
* This option is feasible when placing a new order.

24



	Aluminium
	2000 mm
	Stainless Steel
	75 ÷ 105 kg

Option RI (70477)
Rotary and insulating device.

***Option B**
Locking-unlocking device with control from the floor.
* This option is feasible when placing a new order.

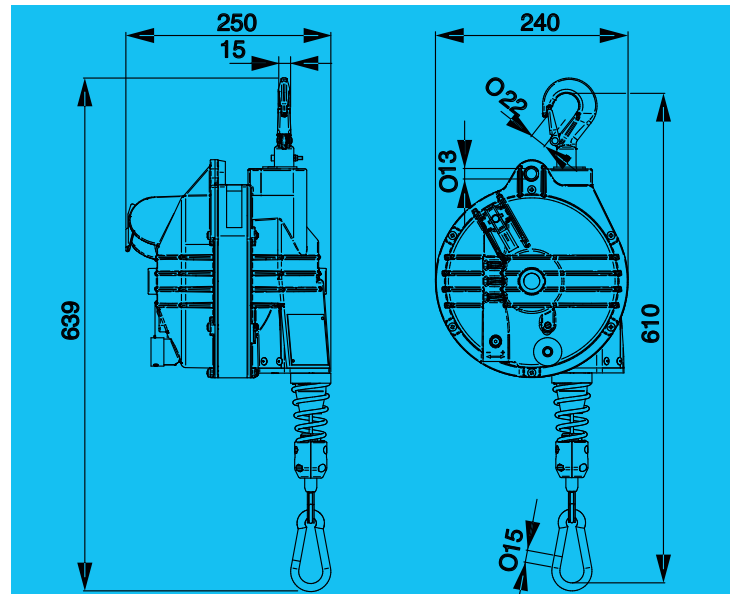
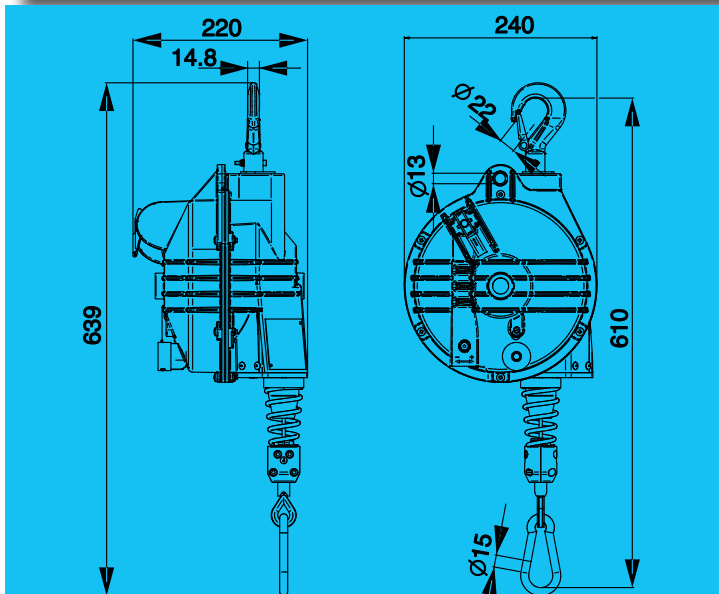

Item	9361	9362	9363	9364	9365	9366	9367	9368	9369
	10 ÷ 15	15 ÷ 20	20 ÷ 25	25 ÷ 30	30 ÷ 35	35 ÷ 45	45 ÷ 55	55 ÷ 65	65 ÷ 75
	9,20	9,50	9,80	10,20	10,60	11,00	11,30	12,30	13,20

9370	9371
75 ÷ 90	90 ÷ 105
16,10	17,20

25



	Aluminium/Rubber
	2000 mm
Stainless Steel	
	10÷75 kg

Option RI (70477)
Rotary and insulating device.

***Option B**
Locking-unlocking device with control from the floor.
* This option is feasible when placing a new order.

26



	Aluminium/Rubber
	2000 mm
Stainless Steel	
	75÷105 kg

Option RI (70477)
Rotary and insulating device.

***Option B**
Locking-unlocking device with control from the floor.
* This option is feasible when placing a new order.

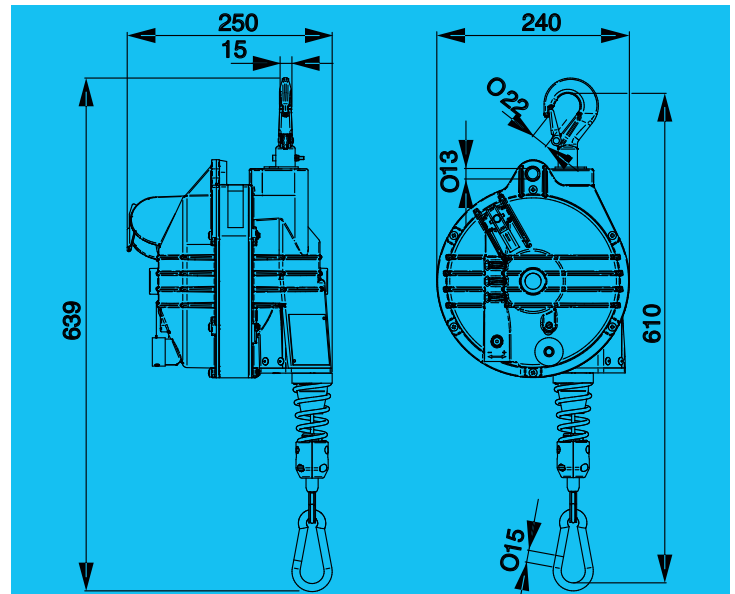
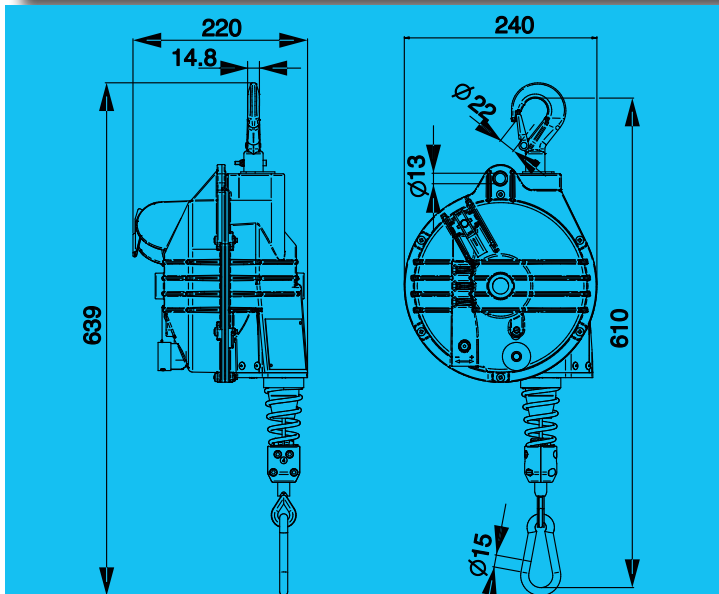

Item	9361G	9362G	9363G	9364G	9365G	9366G	9367G	9368G	9369G
	10÷15	15÷20	20÷25	25÷30	30÷35	35÷45	45÷55	55÷65	65÷75
	10,30	10,60	10,90	11,30	11,70	12,10	12,40	13,40	14,30

	9370G	9371G
	75÷90	90÷105
	17,20	18,30



	Aluminium	
	2500 mm	9401 ÷ 9405
	3000 mm	9431 ÷ 9433
	Stainless Steel	
	15 ÷ 60 kg	

Option RI (70477)
Rotary and insulating device.

***Option B**
Locking-unlocking device with control from the floor.
*This option is feasible when placing a new order.

***Option B1**
Reinforced Locking-unlocking device with control from the floor.
*This option is feasible when placing a new order.

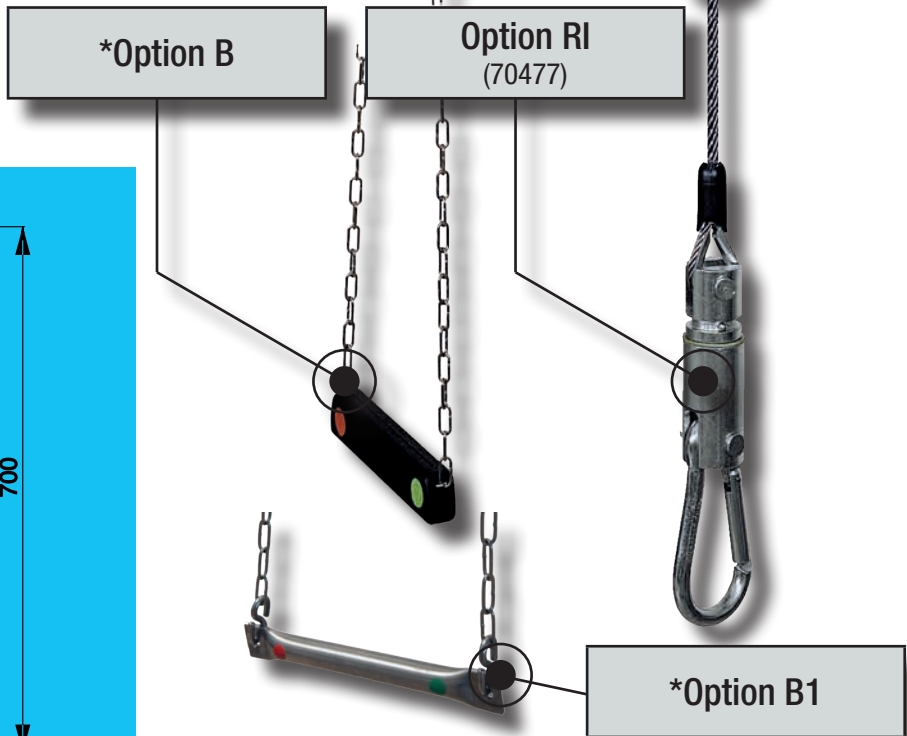
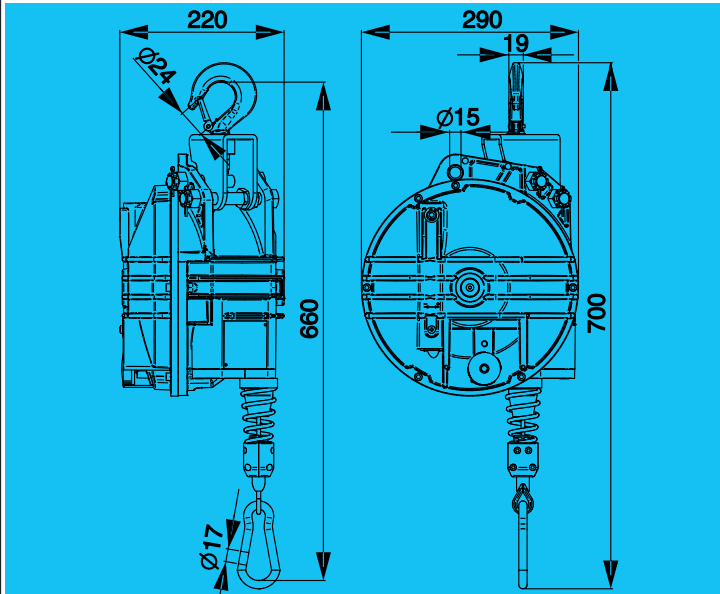

Item	9401	9402	9403	9404	9405
	15 ÷ 20	20 ÷ 30	30 ÷ 40	40 ÷ 50	50 ÷ 60
	19,67	21,11	21,11	22,03	23,07

9431	9432	9433
15 ÷ 20	20 ÷ 25	25 ÷ 35
19,67	19,67	21,11

28



	Aluminium/Rubber	
	2500 mm	9401G÷9405G
	3000 mm	9431G÷9433G
	Stainless Steel	
	15÷60 kg	

Option RI (70477)

Rotary and insulating device.

***Option B**

Locking-unlocking device with control from the floor.

*This option is feasible when placing a new order.

***Option B1**

Reinforced Locking-unlocking device with control from the floor.

*This option is feasible when placing a new order.

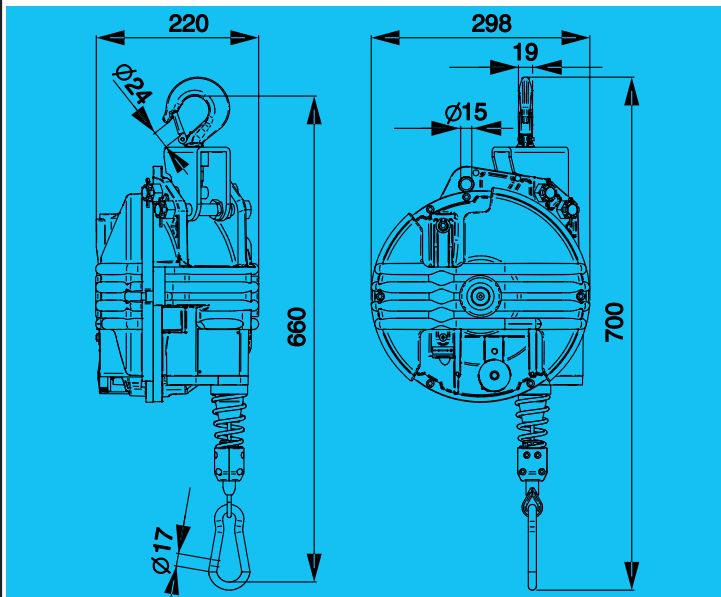

Item	9401G	9402G	9403G	9404G	9405G
	15÷20	20÷30	30÷40	40÷50	50÷60
	20,75	22,19	22,19	23,12	24,15

9431G	9432G	9433G
15÷20	20÷25	25÷35
20,75	20,75	22,19

29



	Aluminium	
	2500 mm	9411÷9414
	3000 mm	9434÷9444
	Stainless Steel	
	35÷100 kg	

Option RI (70477)

Rotary and insulating device.

***Option B**

Locking-unlocking device with control from the floor.

*This option is feasible when placing a new order.

***Option B1**

Reinforced Locking-unlocking device with control from the floor.

*This option is feasible when placing a new order.

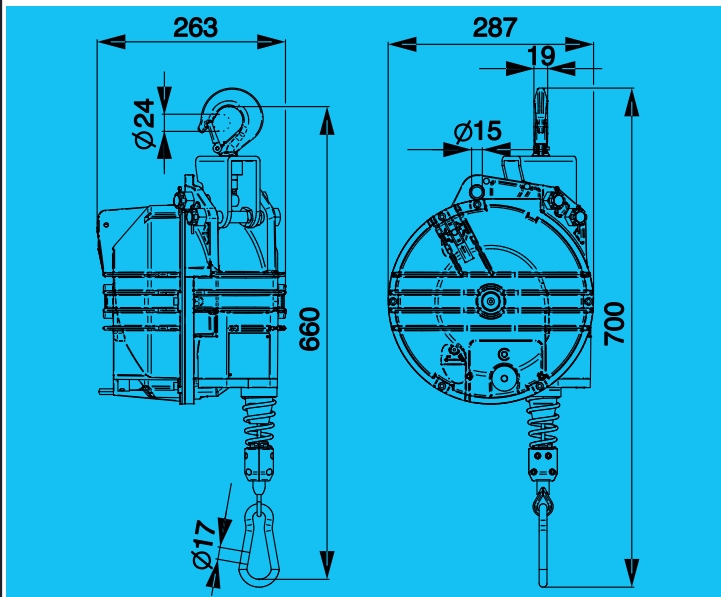

Item	9411	9412	9413	9414
	60÷70	70÷80	80÷90	90÷100
	25,56	26,75	27,90	28,46

9434	9435	9436	9441	9442	9443	9444
35÷45	40÷50	50÷60	60÷70	70÷80	80÷90	80÷100
24,46	23,64	24,69	25,56	26,75	27,90	28,46

30



	Aluminium/Rubber	
	2500 mm	9411G÷9414G
	3000 mm	9434G÷9444G
	Stainless Steel	
	35÷100 kg	

Option RI (70477)

Rotary and insulating device.

***Option B**

Locking-unlocking device with control from the floor.

*This option is feasible when placing a new order.

***Option B1**

Reinforced Locking-unlocking device with control from the floor.

*This option is feasible when placing a new order.

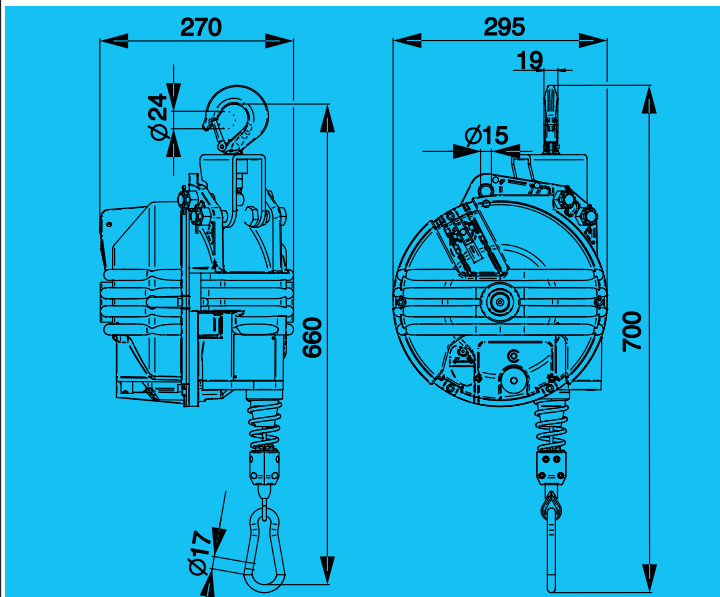

Item	9411G	9412G	9413G	9414G
	60÷70	70÷80	80÷90	90÷100
	26,79	27,98	29,13	29,69

9434G	9435G	9436G	9441G	9442G	9443G	9444G
35÷45	40÷50	50÷60	60÷70	70÷80	80÷90	80÷100
25,69	24,88	25,91	26,79	27,98	29,13	29,69

31



	Aluminium	
	2500 mm	9422÷9426
	3000 mm	9451÷9456
	Stainless Steel	
	100÷180 kg	

Option RI (70477)

Rotary and insulating device.

***Option B**

Locking-unlocking device with control from the floor.

*This option is feasible when placing a new order.

***Option B1**

Reinforced Locking-unlocking device with control from the floor.

*This option is feasible when placing a new order.

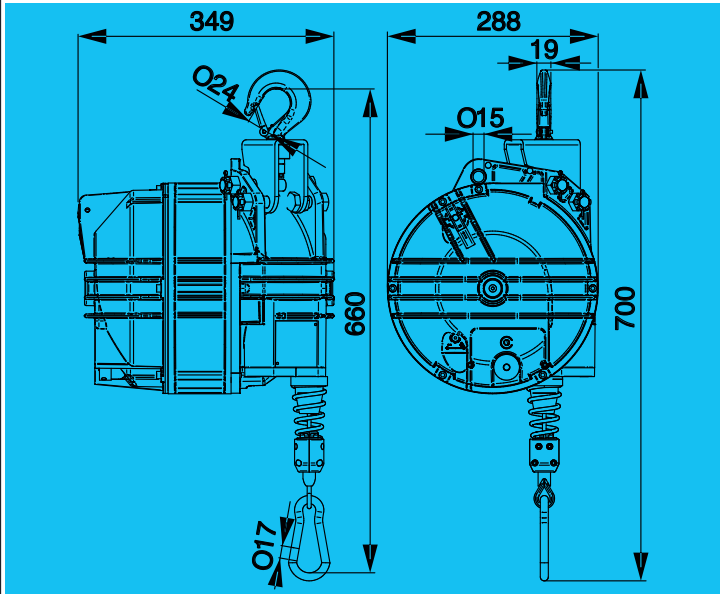

Item	9422	9423	9424	9425	9426
**	100÷120	120÷140	130÷150	140÷160	160÷180
	36,61	38,51	38,83	40,90	43,20

9451	9452	9453	9454	9455	9456
100÷115	115÷130	130÷140	140÷150	150÷160	160÷180
36,61	36,77	38,51	38,83	40,90	43,20

32



	Aluminium/Rubber	
	2500 mm	9422G÷9426G
	3000 mm	9451G÷9456G
	Stainless Steel	
	100÷180 kg	



Option RI (70477)

Rotary and insulating device.

***Option B**

Locking-unlocking device with control from the floor.

*This option is feasible when placing a new order.

***Option B1**

Reinforced Locking-unlocking device with control from the floor.

*This option is feasible when placing a new order.

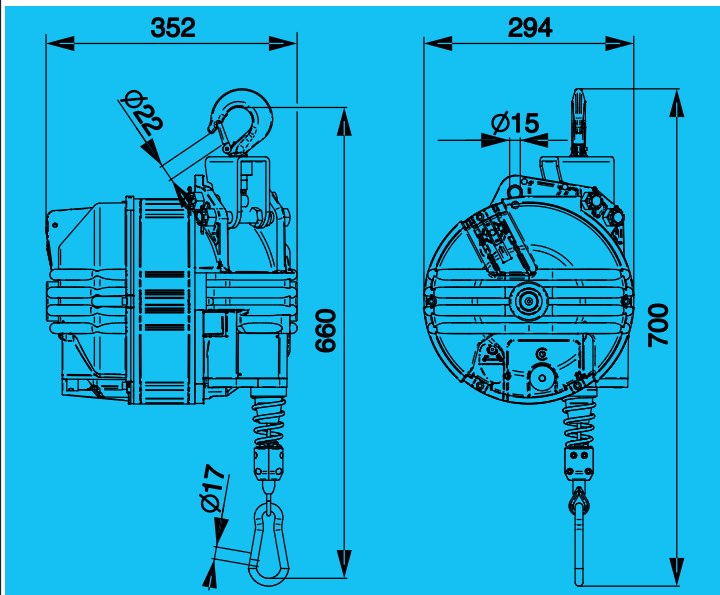

Item	9422G	9423G	9424G	9425G	9426G
**	100÷120	120÷140	130÷150	140÷160	160÷180
	37,83	39,74	40,06	42,13	44,43

9451G	9452G	9453G	9454G	9455G	9456G
100÷115	115÷130	130÷140	140÷150	150÷160	160÷180
37,83	37,99	39,74	40,06	42,13	44,43

BALANCERS TECHNICAL FEATURES

	9354÷9359 9354G÷9359G	9502÷9509	9520÷9525	9361÷9369 9361G÷9369G 9370/9371 93710/9371G	9401÷9405 9401G÷9405G 9411÷9414 9411G÷9414G 9422÷9426 9422G÷9426G	9431÷9433 9431G÷9433G 9434÷9444 9434G÷9444G 9451÷9456 9451G÷9456G	
kg	4÷25	20÷100	12÷70	10÷105	15÷180	15÷180	Capacity
mm	2000	2100	2700	2000	2500	3000	Stroke
●	●	●	●	●	●	●	Ribbed and sealed construction in aluminium alloy
●	●	●	●	●	●	●	Stainless steel rope
●	●	●	●	●	●	●	Adjustable capacity by means of a worm screw
●	●	●	●	●	●	●	Safety suspension
●	●	●	●	●	●	●	Safety device against load dropping due to the spring breakage (capacity >3kg)
				●	●	●	Centrifugal safety device
●	●	●	●	●	●	●	Upper rotary suspension with safety hook
●	●	●	●	●	●	●	Locking device to block the load at any height
●	●	●	●	●	●	●	Adjustable stroke limiting device
●	●	●	●	●	●	●	Taper drum rotating on ball bearings
●	●	●	●	●	●	●	Cable guide in antifriction material
●	●	●	●	●	●	●	Rotary upper hook with ball bearing
					●	●	Lining up upper hook
					●	●	Visible cable for inspection
●	●	●	●	●	●	●	Inert spring drum assembly
				●			Polyamides thimble

ON REQUEST OPTIONS B - B1 - RI - F - 32952

B		●	●	* ●	* ●	* ●	B: Locking-unlocking device with control from the floor
B1					* ●	* ●	B1: Reinforced Locking-unlocking device with control from the floor
RI	●	●	●	●	●	●	70477: Rotary insulated hook
F	* ●	* ●	* ●				F: Brake device
32952	●						Flexible cables holder (Max. load capacity 25kg)

* This option is feasible when placing a new order while it is not possible to assemble this device on balancers already installed.

PACKAGING FEATURES

	9354 (G)	9355 (G)	9356 (G)	9357 (G)	9358 (G)	9359 (G)	9502	9503	9504	9505	9506
kg	6,00	6,40	6,80	7,40	7,00	7,60	14,40	17,00	17,30	18,50	17,30
lb	13,23	14,11	14,99	16,31	15,43	16,76	31,75	37,48	31,14	40,79	38,14
mm	525x206x175	525x206x175	525x206x175	525x206x175	525x206x175	525x206x175	590x265x260	590x265x260	590x265x260	590x265x260	590x265x260
inch	16,5x8,1x6,5	16,5x8,1x6,5	16,5x8,1x6,5	16,5x8,1x6,5	16,5x8,1x6,5	16,5x8,1x6,5	17,9x10,6x11	17,9x10,6x11	17,9x10,6x11	17,9x10,6x11	17,9x10,6x11
●	20/21	20/21	20/21	20/21	20/21	20/21	22	22	22	22	22
	9507	9508	9509	9520	9521	9522	9523	9524	9525	9361 (G)	9362 (G)
kg	19,50	18,00	18,60	14,60	14,40	17,60	17,20	18,40	17,50	11,80	12,10
lb	43,00	39,68	41,01	32,19	31,75	38,80	38,00	40,57	38,58	26,01	26,68
mm	590x265x260	590x265x260	590x265x260	590x265x260	590x265x260	590x265x260	590x265x260	590x265x260	590x265x260	590x265x260	590x265x260
inch	17,9x10,6x11	17,9x10,6x11	17,9x10,6x11	17,9x10,6x11	17,9x10,6x11	17,9x10,6x11	17,9x10,6x11	17,9x10,6x11	17,9x10,6x11	17,9x10,6x11,0	17,9x10,6x11,0
●	22	22	22	22	22	22	22	22	22	23/25	23/25
	9363 (G)	9364 (G)	9365 (G)	9366 (G)	9367 (G)	9368 (G)	9369 (G)	9370 (G)	9371 (G)	9401 (G)	9402 (G)
kg	12,40	13,30	13,30	14,10	14,10	15,00	15,80	18,80	19,70	22,70	24,10
lb	27,34	29,32	31,09	31,09	31,09	33,07	34,83	41,45	39,46	50,04	53,13
mm	590x265x260	590x265x260	590x265x260	590x265x260	590x265x260	590x265x260	590x265x260	590x265x260	590x265x260	670x295x286	670x295x286
inch	17,9x10,6x11,0	17,9x10,6x11,0	17,9x10,6x11,0	17,9x10,6x11,0	17,9x10,6x11,0	17,9x10,6x11,0	17,9x10,6x11,0	17,9x10,6x11,0	17,9x10,6x11,0	23,6x12,6x13	23,6x12,6x13
●	23/25	23/25	23/25	23/25	23/25	23/25	23/25	24/26	24/26	27/28	27/28
	9403 (G)	9404 (G)	9405 (G)	9411 (G)	9412 (G)	9413 (G)	9414 (G)	9422 (G)	9423 (G)	9424 (G)	9425 (G)
kg	24,10	25,10	26,10	28,50	29,70	30,80	31,40	40,00	41,90	42,20	44,30
lb	53,13	55,34	57,54	62,83	65,48	67,90	69,23	88,18	92,37	93,04	97,66
mm	670x295x286	670x295x286	670x295x286	670x295x286	670x295x286	670x295x286	670x295x286	670x300x360	670x300x360	670x300x360	670x300x360
inch	23,6x12,6x13	23,6x12,6x13	23,6x12,6x13	23,6x12,6x13	23,6x12,6x13	23,6x12,6x13	23,6x12,6x13	23,6x12,6x16,5	23,6x12,6x16,5	23,6x12,6x16,5	23,6x12,6x16,5
●	27/28	27/28	27/28	29/30	29/30	29/30	29/30	31/32	31/32	31/32	31/32
	9426 (G)	9431 (G)	9432 (G)	9433 (G)	9434 (G)	9435 (G)	9436 (G)	9441 (G)	9442 (G)	9443 (G)	9444 (G)
kg	46,60	22,70	22,70	24,10	27,50	26,60	27,60	28,50	29,70	30,80	31,40
lb	102,74	50,04	50,04	53,13	60,63	58,64	60,85	62,83	65,48	67,90	69,23
mm	670x300x360	670x295x286	670x295x286	670x295x286	670x295x286	670x295x286	670x295x286	670x295x286	670x295x286	670x295x286	670x295x286
inch	23,6x12,6x16,5	23,6x12,6x13	23,6x12,6x13	23,6x12,6x13	23,6x12,6x13	23,6x12,6x13	23,6x12,6x13	23,6x12,6x13	23,6x12,6x13	23,6x12,6x13	23,6x12,6x13
●	31/32	29/30	29/30	29/30	29/30	29/30	29/30	29/30	29/30	29/30	29/30
	9451 (G)	9452 (G)	9453 (G)	9454 (G)	9455 (G)	9456 (G)					
kg	40,00	40,10	41,90	42,20	44,30	46,60					
lb	88,18	88,41	92,37	93,04	97,66	102,74					
mm	670x300x360	670x300x360	670x300x360	670x300x360	670x300x360	670x300x360					
inch	23,6x12,6x16,5	23,6x12,6x16,5	23,6x12,6x16,5	23,6x12,6x16,5	23,6x12,6x16,5	23,6x12,6x16,5					
●	31/32	31/32	31/32	31/32	31/32	31/32					

EXTENSIONS CABLES FOR BALANCERS

mm / inch

EXTENSIONS CABLES (carabiner 40mm-1.57")

9301 ÷ 9303 - 9311 ÷ 9313

9301NY ÷ 9303NY - 9311NY ÷ 9313NY

(L) MM	CODE (Stainless steel rope Ø 2-0.08")	CODE NY (Nylon rope Ø 2-0.08")	(L) inch
500	72965/0,5	7260000250	19.68
1000	72965/1	7260000251	39.37
2500	72965/2,5	7260000252	98.42
3000	72965/3	7260000253	118.11
5000	72965/5	7260000254	196.85

EXTENSIONS CABLES (carabiner 60mm-2.36")

9320 ÷ 9323

9320NY ÷ 9323NY

(L) MM	CODE (Stainless steel rope Ø 2-0.08")	CODE NY (Nylon rope Ø 3-0.12")	(L) inch
500	72965/0,5	7260000260	19.68
1000	72965/1	7260000261	39.37
2500	72965/2,5	7260000262	98.42
3000	72965/3	7260000263	118.11
5000	72965/5	7260000264	196.85

EXTENSIONS CABLES (carabiner 80mm-3.14")

9336L ÷ 9350

9336LNY ÷ 9350NY

(L) MM	CODE (Stainless steel rope Ø 2,5-0.10")	CODE NY (Nylon rope Ø 3-0.12")	(L) inch
500	72966/0,5	7260000270	19.68
1000	72966/1	7260000271	39.37
2500	72966/2,5	7260000272	98.42
3000	72966/3	7260000273	118.11
5000	72966/5	7260000274	196.85

EXTENSIONS CABLES (carabiner 80mm-3.14")

9354 ÷ 9359

(L) MM	CODE (Stainless steel rope Ø 3-0.12")	(L) inch
500	72967/0,5	19.68
1000	72967/1	39.37
2500	72967/2,5	98.42
3000	72967/3	118.11
5000	72967/5	196.85

EXTENSIONS CABLES (carabiner 100mm-3.94")

9361 ÷ 9371 - 9520 ÷ 9525

(L) MM	CODE (Stainless steel rope Ø 4-0.16")	(L) inch
500	72968/0,5	19.68
1000	72968/1	39.37
2500	72968/2,5	98.42
3000	72968/3	118.11
5000	72968/5	196.85

EXTENSIONS CABLES (carabiner 100mm-3.94")

9502 ÷ 9509

(L) MM	CODE (Stainless steel rope Ø 5-0.20")	(L) inch
500	72969/0,5	19.68
1000	72969/1	39.37
2500	72969/2,5	98.42
3000	72969/3	118.11
5000	72969/5	196.85

EXTENSIONS CABLES (carabiner 120mm-4.72")

94XX

(L) MM	CODE (Stainless steel rope Ø 5-0.20")	(L) inch
500	72969/0,5/120	19.68
1000	72969/1/120	39.37
2500	72969/2,5/120	98.42
3000	72969/3/120	118.11
5000	72969/5/120	196.85

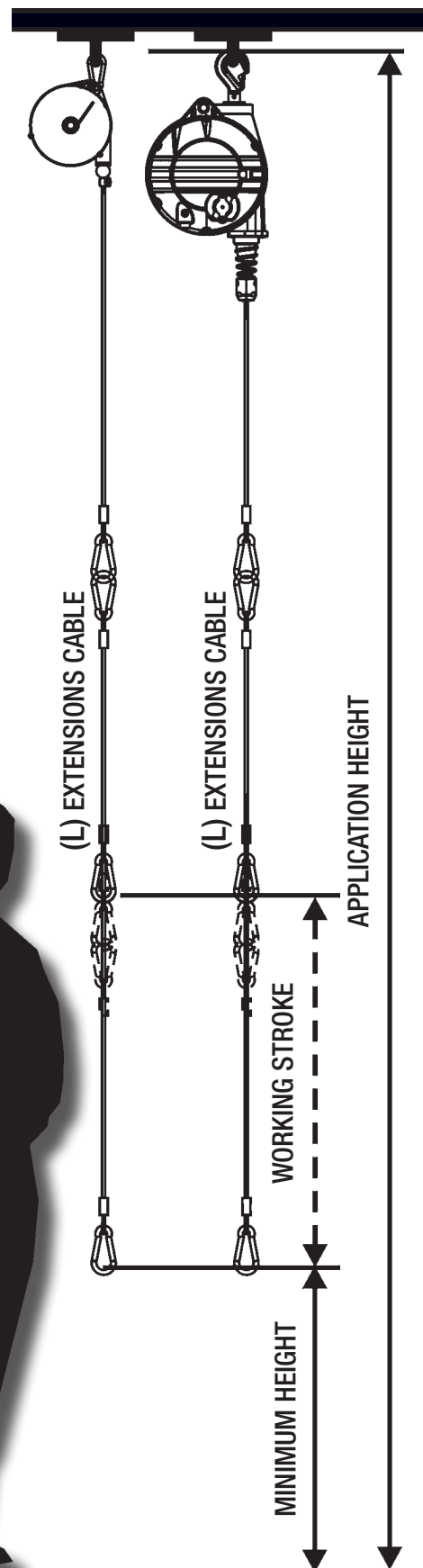

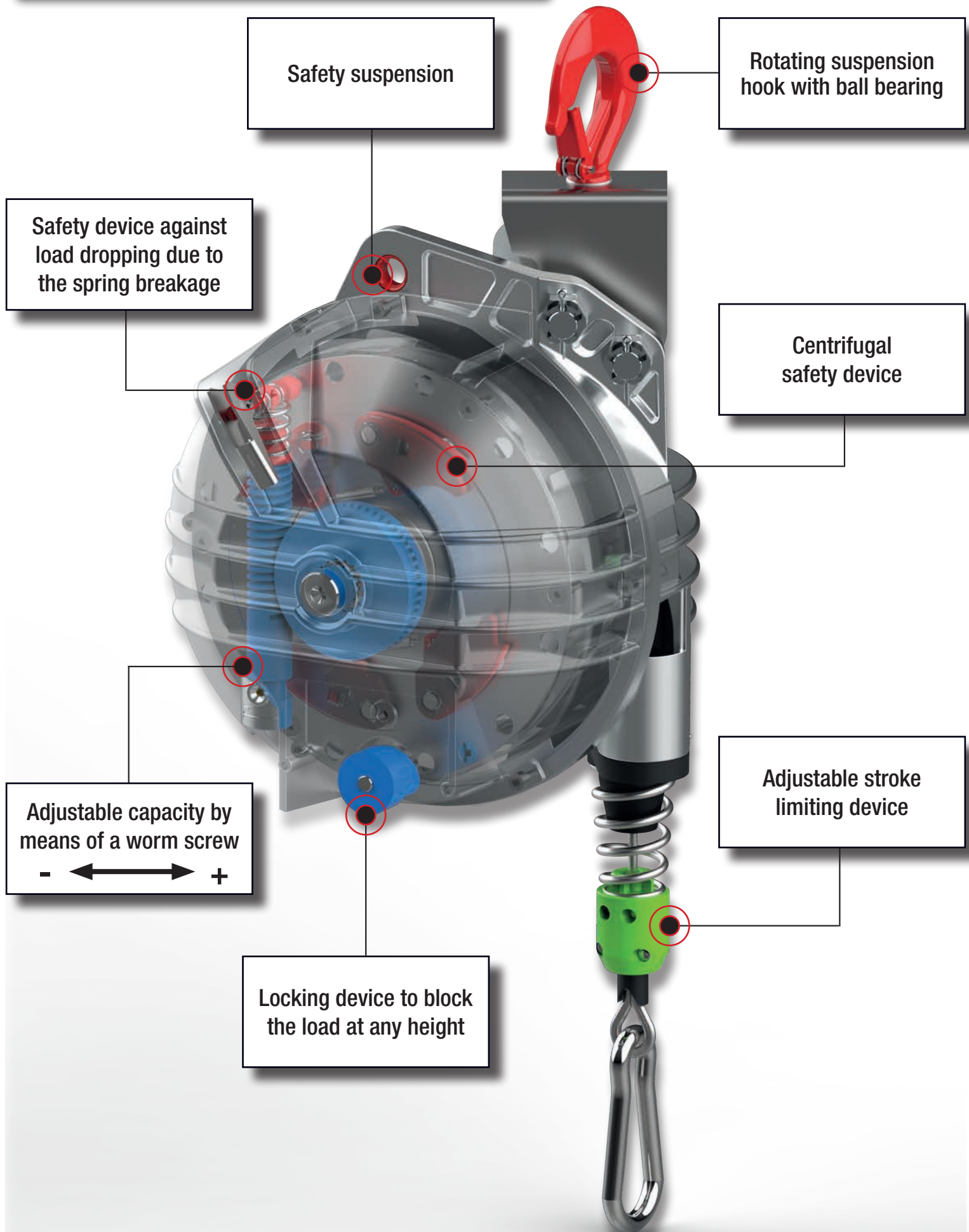



ITEM

kg / lb - mm / inch

	G	NY	AX	ESD	IL RL						
						Kg	lb	mm	inch	Kg	lb
9300		NY				0,2÷0,5	0,44÷1,1	1600	62,99	0,43	0,95
9301		NY				0,4÷1	0,88÷2,20	1600	62,99	0,46	1,01
9302		NY				1÷2	2,20÷4,41	1600	62,99	0,49	1,08
9303		NY				2÷3	4,41÷6,61	1600	62,99	0,64	1,41
9310		NY	AX	ESD	IL	0,2÷0,5	0,44÷1,1	1600	62,99	0,55	1,21
9311		NY	AX	ESD	IL	0,4÷1	0,88÷2,20	1600	62,99	0,57	1,26
9312		NY	AX	ESD	IL	1÷2	2,20÷4,41	1600	62,99	0,60	1,32
9313		NY	AX	ESD	IL	2÷3	4,41÷6,61	1600	62,99	0,74	1,63
9320		NY	AX	ESD	IL	1÷2,5	2,20÷5,51	2000	78,74	1,67	3,68
9321		NY	AX	ESD	IL	2÷4	4,41÷8,82	2000	78,74	1,90	4,19
9322		NY	AX	ESD	IL	4÷6	8,82÷13,23	2000	78,74	1,98	4,37
9323		NY	AX	ESD	IL	6÷8	13,23÷17,63	2000	78,74	2,28	5,03
9336L		NY	AX	ESD	IL	0,5÷2	1,1÷4,41	2500	98,43	3,14	6,92
9336		NY	AX	ESD	IL	2÷4	4,41÷8,82	2500	98,43	3,14	6,92
9337		NY	AX	ESD	IL	4÷6	8,82÷13,23	2500	98,43	3,30	7,28
9338		NY	AX	ESD	IL	6÷8	13,23÷17,63	2500	98,43	3,36	7,41
9339		NY	AX	ESD	IL	8÷10	17,63÷22,05	2500	98,43	3,43	7,56
9340		NY	AX	ESD	IL	10÷14	22,05÷30,86	2500	98,43	3,58	7,89
9346L		NY	AX	ESD	IL	0,5÷2	1,1÷4,41	2500	98,43	3,14	6,92
9346		NY	AX	ESD	IL	2÷4	4,41÷8,82	2500	98,43	3,14	6,92
9347		NY	AX	ESD	IL	4÷6	8,82÷13,23	2500	98,43	3,32	7,32
9348		NY	AX	ESD	IL	6÷8	13,23÷17,63	2500	98,43	3,38	7,45
9349		NY	AX	ESD	IL	8÷10	17,63÷22,05	2500	98,43	3,48	7,67
9350		NY	AX	ESD	IL	10÷14	22,05÷30,86	2500	98,43	3,62	7,98
9354	G		AX	ESD	RL	4÷7	8,82÷15,43	2000	78,74	4,94	10,89
9355	G		AX	ESD	RL	7÷10	15,43÷22,05	2000	78,74	5,30	11,68
9356	G		AX	ESD	RL	10÷14	22,05÷30,86	2000	78,74	5,67	12,5
9357	G		AX	ESD	RL	14÷18	30,86÷39,68	2000	78,74	6,26	13,8
9358	G		AX	ESD	RL	18÷22	39,68÷48,50	2000	78,74	5,89	12,99
9359	G		AX	ESD	RL	22÷25	48,50÷55,12	2000	78,74	6,53	14,4
9361	G				RL	10÷15	22,05÷33,07	2000	78,74	9,91	21,85
9362	G				RL	15÷20	33,07÷44,10	2000	78,74	10,20	22,49
9363	G				RL	20÷25	44,10÷55,12	2000	78,74	10,48	23,1
9364	G				RL	25÷30	55,12÷66,14	2000	78,74	11,32	24,96
9365	G				RL	30÷35	66,14÷77,16	2000	78,74	11,32	24,96
9366	G				RL	35÷45	77,16÷99,21	2000	78,74	12,21	26,92
9367	G				RL	45÷55	99,21÷121,25	2000	78,74	12,21	26,92
9368	G				RL	55÷65	121,25÷143,3	2000	78,74	13,06	28,79
9369	G				RL	65÷75	143,3÷165,35	2000	78,74	13,86	30,56
9370	G					75÷90	165,35÷198,42	2000	78,74	16,84	37,13
9371	G					90÷105	198,42÷231,49	2000	78,74	17,77	39,18
9401	G				RL	15÷20	33,07÷44,10	2500	98,43	19,67	43,36
9402	G				RL	20÷30	44,10÷66,14	2500	98,43	21,11	46,54
9403	G				RL	30÷40	66,14÷88,18	2500	98,43	21,11	46,54
9404	G				RL	40÷50	88,18÷110,23	2500	98,43	22,03	48,57
9405	G				RL	50÷60	110,23÷132,28	2500	98,43	23,07	50,86

ITEM

kg / lb - mm / inch

	G	NY	AX	ESD	IL RL						
						Kg	lb	mm	inch	Kg	lb
9431	G				RL	15÷20	33,07÷44,10	3000	118,11	19,67	43,36
9432	G				RL	20÷25	44,10÷55,12	3000	118,11	19,67	43,36
9433	G				RL	25÷35	55,12÷77,16	3000	118,11	21,11	46,54

9411	G				RL	60÷70	132,28÷132,28	2500	98,43	25,56	56,35
9412	G				RL	70÷80	132,28÷176,37	2500	98,43	26,75	58,97
9413	G				RL	80÷90	176,37÷198,42	2500	98,43	27,90	61,51
9414	G				RL	90÷100	198,42÷220,46	2500	98,43	28,46	62,74

9434	G				RL	35÷45	77,16÷99,21	3000	118,11	24,46	53,93
9435	G				RL	40÷50	88,18÷110,23	3000	118,11	23,65	52,14
9436	G				RL	50÷60	110,23÷132,28	3000	118,11	24,69	54,43
9441	G				RL	60÷70	132,28÷132,28	3000	118,11	25,56	56,35
9442	G				RL	70÷80	132,28÷176,37	3000	118,11	26,75	58,97
9443	G				RL	80÷90	176,37÷198,42	3000	118,11	27,90	61,51
9444	G				RL	80÷100	176,37÷220,46	3000	118,11	28,46	62,74

9422	G				RL	100÷120	220,46÷264,56	2500	98,43	36,61	80,73
9423	G				RL	120÷140	264,56÷308,65	2500	98,43	38,51	84,9
9424	G				RL	130÷150	308,65÷330,69	2500	98,43	38,83	85,61
9425	G				RL	140÷160	330,69÷352,74	2500	98,43	40,90	90,17
9426	G				RL	160÷180	352,74÷396,83	2500	98,43	43,20	95,24

9451	G				RL	100÷115	220,46÷253,53	3000	118,11	36,61	80,71
9452	G				RL	115÷130	253,53÷308,65	3000	118,11	36,77	81,06
9453	G				RL	130÷140	308,65÷330,69	3000	118,11	38,51	84,9
9454	G				RL	140÷150	330,69÷330,69	3000	118,11	38,83	85,61
9455	G				RL	150÷160	330,69÷352,74	3000	118,11	40,90	90,17
9456	G				RL	160÷180	352,74÷396,83	3000	118,11	43,20	95,24

9502			AX	ESD	RL	20÷30	44,10÷66,14	2100	82,68	12,60	27,78
9503			AX	ESD	RL	30÷40	66,14÷88,18	2100	82,68	15,20	33,51
9504			AX	ESD	RL	40÷50	88,18÷110,23	2100	82,68	15,50	34,17
9505			AX	ESD	RL	50÷60	110,23÷132,28	2100	82,68	16,70	36,82
9506			AX	ESD	RL	60÷70	132,28÷132,28	2100	82,68	15,50	34,17
9507			AX	ESD	RL	70÷80	132,28÷176,37	2100	82,68	17,70	39,02
9508			AX	ESD	RL	80÷90	176,37÷198,42	2100	82,68	16,20	35,71
9509			AX	ESD	RL	80÷100	176,37÷220,46	2100	82,68	16,80	37,04

9520			AX	ESD	RL	12÷20	26,46÷44,10	2700	106,3	12,80	28,22
9521			AX	ESD	RL	20÷30	44,10÷66,14	2700	106,3	12,60	27,78
9522			AX	ESD	RL	30÷40	66,14÷88,18	2700	106,3	15,80	34,83
9523			AX	ESD	RL	40÷50	88,18÷110,23	2700	106,3	15,40	33,95
9524			AX	ESD	RL	50÷60	110,23÷132,28	2700	106,3	16,60	36,6
9525			AX	ESD	RL	60÷70	132,28÷132,28	2700	106,3	15,70	34,61

9200						0,4÷0,8	0,88÷1,76	1350	53,15	1,10	2,43
9201						0,75÷1,5	1,65÷3,31	1350	53,15	1,10	2,43
9202						1,2÷2,5	2,65÷5,51	1350	53,15	1,30	2,87
9203						3÷5	6,61÷11,02	900	35,43	1,30	2,87

APPLICATION LIST

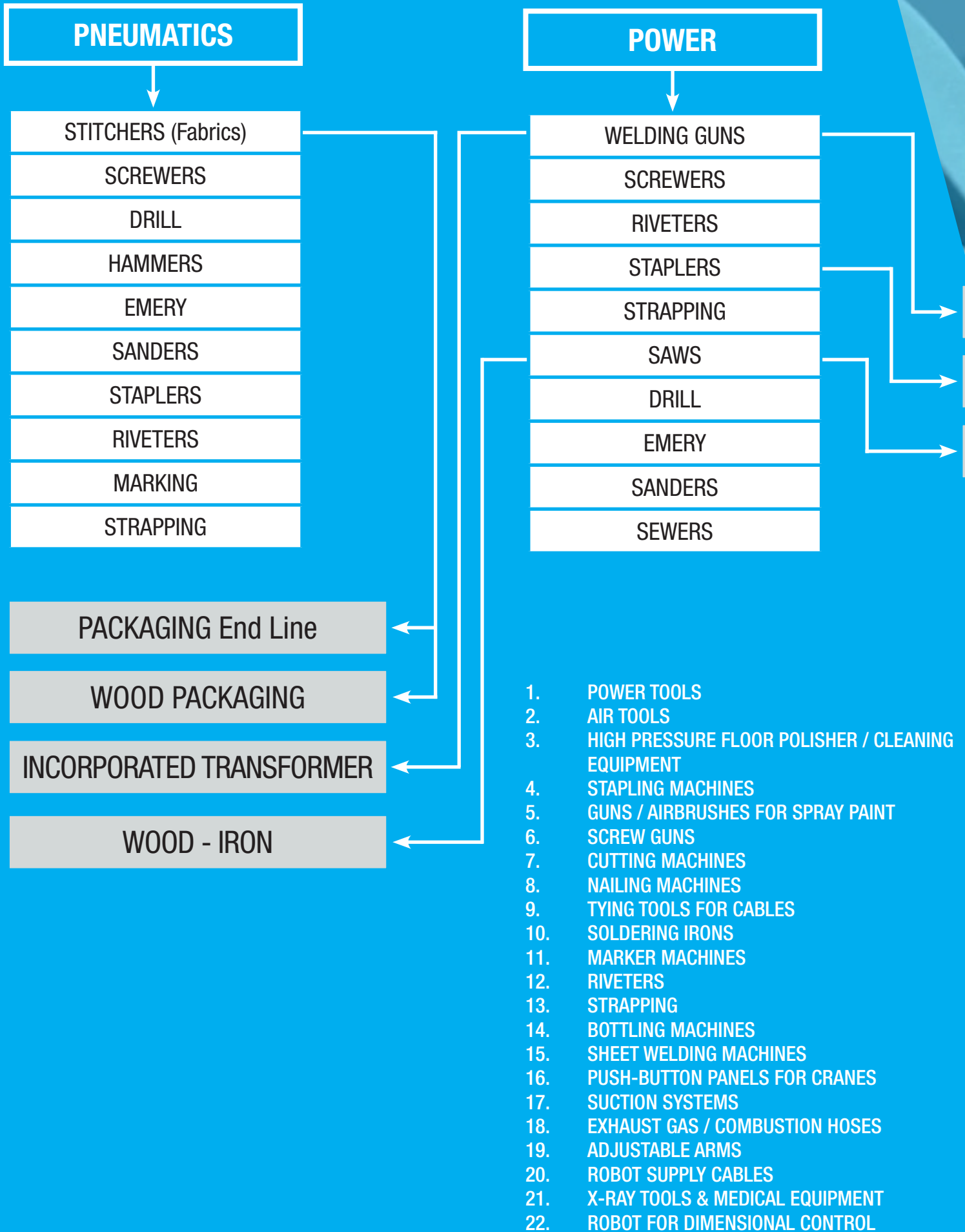

HYDRAULIC



RIVETERS

CLINCIATRICI

HYDRAULIC WRENCHES

SEPARATE TRANSFORMER

PACKING CARTONS

SLAUGHTER

SPECIAL APPLICATIONS

IRONS

VACUUM CLEANERS

SPORTS TOOLS

CLOSE DOOR

CABLE GUIDE

FUEL PUMPS

GARDENING

LEATHER PROCESSING

EV CHARGING STATIONS

FOOD&MEAT PROCESSING

ROBOTICS & AUTOMATION

LOGISTICS

TANK WASHING

23. TOOLS FOR SLAUGHTERHOUSES
24. TOOLS FOR WORKING THE ROCKS
25. CONVEYOR BELTS AND RAILS
26. POWER SUPPLY BUSBARS
27. TOOLS FOR WORKING WOOD
28. SUBMERSIBLE PUMPS AND STIRRERS
29. INDUSTRIAL SEWING MACHINES
30. TOOLS FOR PACKING
31. WELDING GUNS
32. WELDING JIGS
33. CALLIPERS FOR HOLES AND MICROMETERS
34. CABLE HOLDER IN ELECTRIC CABINS
35. MONITOR SUSPENSION
36. PIPES FOR PETROL PUMPS
37. HOSES FOR GAS PUMPS
38. FILLING MACHINES FOR THE FOOD INDUSTRY
39. SUSPENSION OF EQUIPMENT FOR LEATHER PROCESSING
40. ELECTRICAL AND PNEUMATIC STAPLERS
41. AIRBRUSHES AND GUNS FOR PAINTING
42. RIVETERS
43. PHOTOGRAPHY/CINEMA/THEATRE
44. REHAB EQUIPMENT

... for all kind
of tools

TECNA Balancers Lines



*Precision Tailored for Every Work Environment
Elevate Your Efficiency Across Industries!*

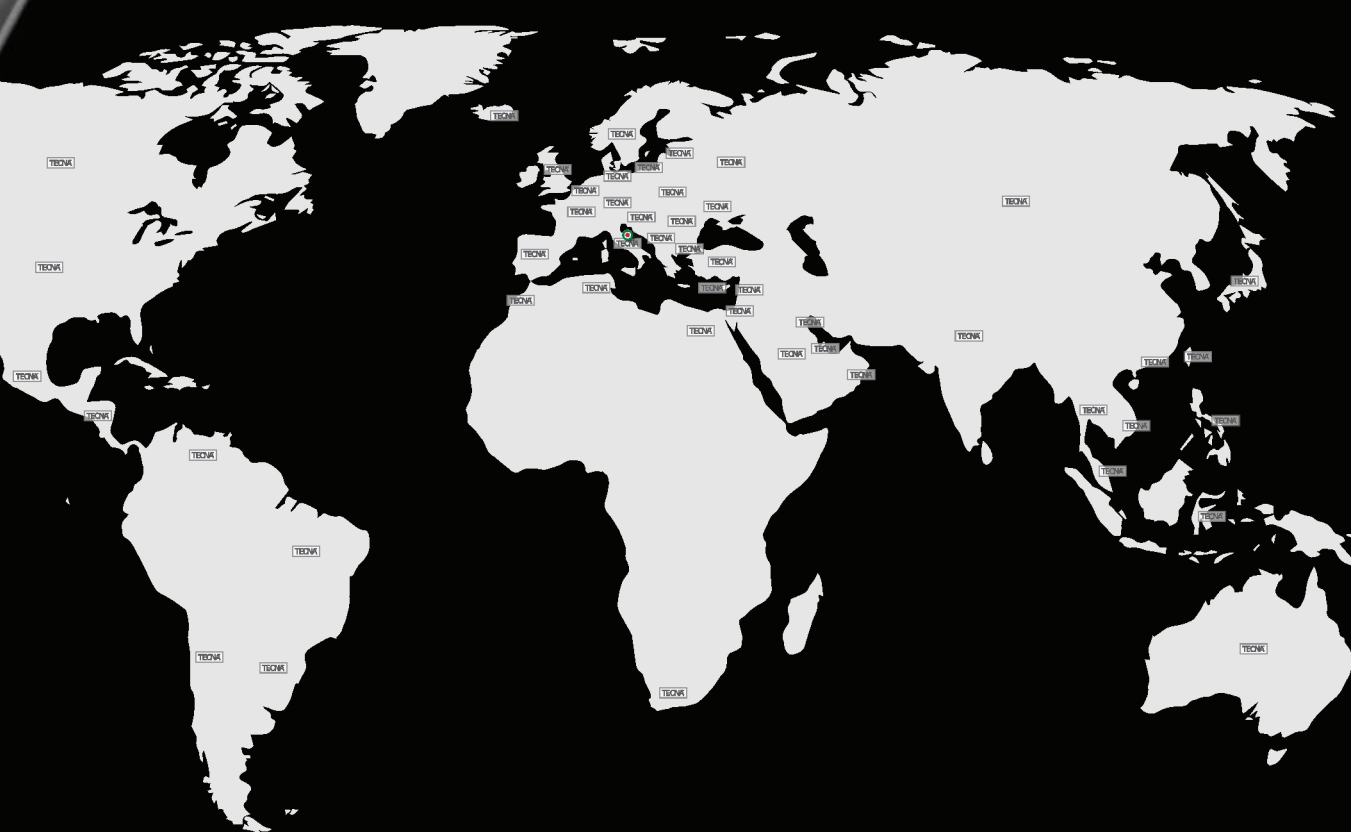

TECNA®

Resistance Welding Systems & Balancers



Via Meucci, 27
40024 - Castel San Pietro Terme (BO)
Italy

Tel. +39 051 695 4411

Fax +39 051 654 4490

vendite@tecna.net

sales@tecna.net



www.tecna.net

Fabbricato in Italia