

TECNA[®]

INDUSTRIAL RESISTANCE WELDING SYSTEMS

THE CUTTING-EDGE TECHNOLOGY FOR RESISTANCE WELDING
A COMMITMENT TO CONTINUOUS IMPROVEMENT

NEW NEW GENERATION ROBOT GUN TRANSFORMERS

SPECIFIC DESIGN FOR HEAVY
DUTY AND
AUTOMOTIVE PRODUCTION

INVERTER
BEST QUALITY WELDS

POWERFUL & STRONG

LIGHTWEIGHT & FLEXIBLE

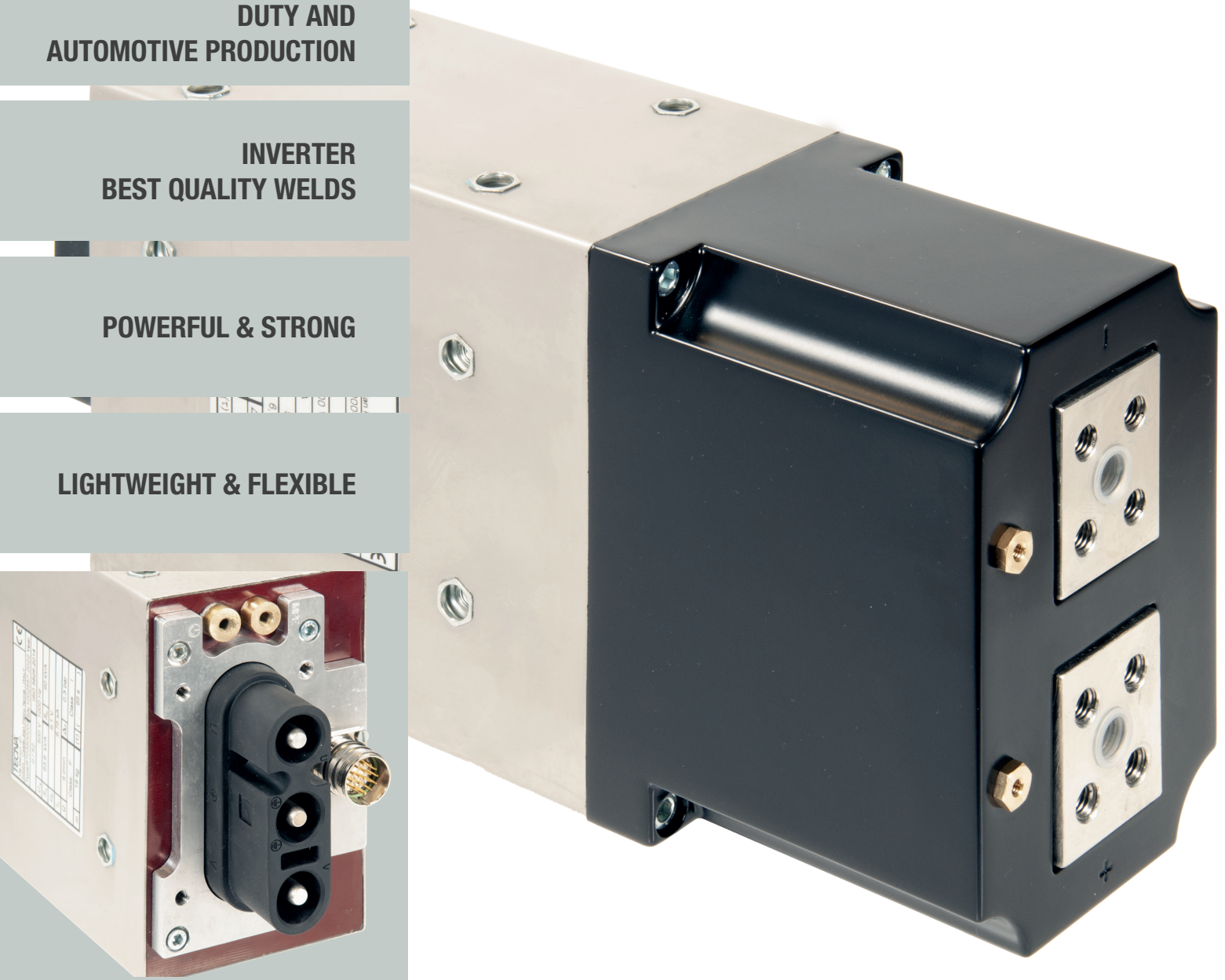

TECNA AVAILABLE MODELS:
LIGHT - HEAVY
90 kVA MF

TECHNICAL SPECIFICATIONS

Item	4000013409	4000013410	4000013411	4000013412
Type	MFDC 90 kVA 400V/50 Hz Light	MFDC 90 kVA 400V/50 Hz Heavy	MFDC 90 kVA 480V/60 Hz Light	MFDC 90 kVA 480V/60 Hz Heavy
S_{1P}	63,6 kVA	63,6 kVA	63,6 kVA	63,6 kVA
U_{20}	9,1 V	9,1 V	9,1 V	9,1 V
I_{2P}^*	6 kA	6,75 kA	6 kA	6,75 kA
U_{1N}	500 V / 1000 Hz	500 V / 1000 Hz	635 V / 1000 Hz	635 V / 1000 Hz
m	16 Kg	17,5 Kg	16 Kg	17,5 Kg

*Q 4 l/min

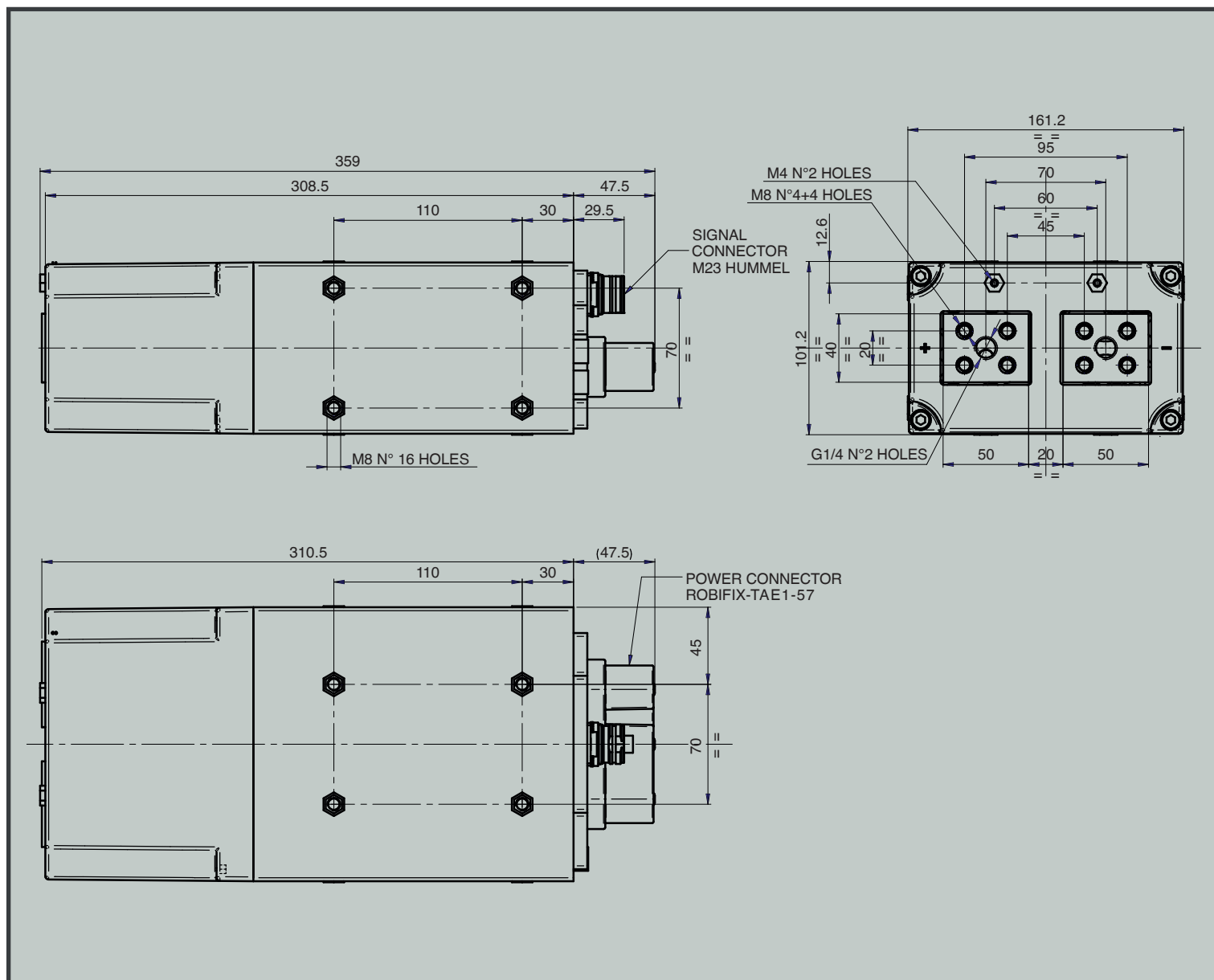

DCT0300001 - EN